

power light source

# LUXEON® K2 with TFFC

## Introduction

LUXEON® K2 with TFFC is the most robust and powerful LED available. With unprecedented thermal, drive current and light output capabilities, it offers lighting industry leading lumens per package and the opportunity to create never before possible lighting solutions. LUXEON K2 with TFFC is available in a wide range of colors, including cool-white, neutral-white, warm-white, blue, royal blue, green and cyan.

- ♦ deliver more useable light
- ♦ optimize applications to reduce size and cost
- ♦ engineer more robust applications
- ♦ reduce thermal management engineering
- ♦ utilize standard FR4 PCB technology in addition to MCPCB solutions
- ♦ simplify manufacturing through the use of surface mount technology.

## LUXEON K2 with TFFC Technology Leadership

- ♦ Industry leading lumen performance, over 200 lumens in Cool-White at 1,000mA
- ♦ Over 55 lm/W at 1,000mA
- ♦ Highest operating junction temperature available, up to 185°C
- ♦ Highest Drive Currents—1500 mA
- ♦ Lowest Thermal Resistance—7°C/W
- ♦ Industry Best Moisture Sensitivity level—JEDEC 2a
- ♦ Lead free reflow solder JEDEC 020c compatible
- ♦ RoHS Compliant
- ♦ Autoclave compliant—JESD22 A-102
- ♦ Industry Best Lumen Maintenance—50,000 hours life at 1000 mA with 70% lumen maintenance

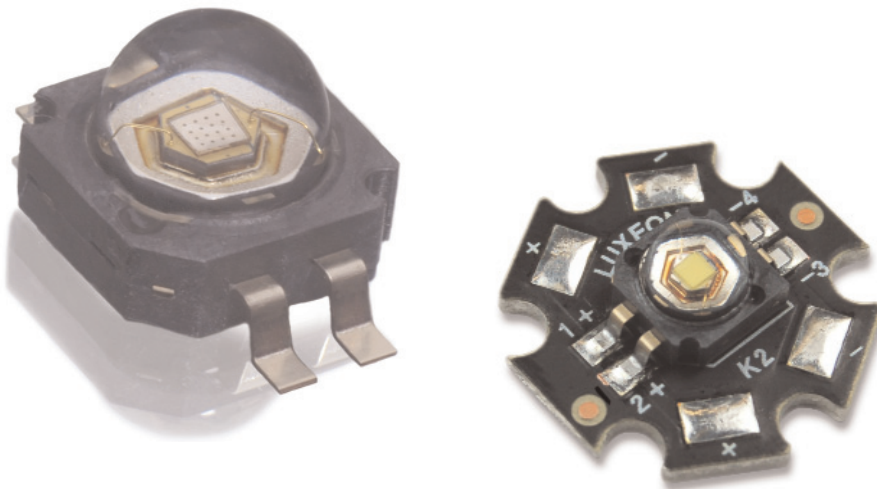

---

## Table of Contents

|   |    |
|---|----|
| Product Nomenclature                                  | 3  |
| Average Lumen Maintenance Characteristics             | 3  |
| Environmental Compliance                              | 3  |
| Flux Characteristics for LUXEON K2 with TFFC          | 4  |
| Flux Characteristics for LUXEON K2 with TFFC Star     | 5  |
| Optical Characteristics                               | 6  |
| Electrical Characteristics                            | 7  |
| Absolute Maximum Ratings                              | 8  |
| JEDEC Moisture Sensitivity                            | 9  |
| Reflow Soldering Characteristics                      | 9  |
| Mechanical Dimensions—SMT 4-Lead Gullwing Form        | 10 |
| Solder Pad Layout—SMT Lead Form                       | 11 |
| Mechanical Dimensions—2-Lead Gullwing Form            | 12 |
| Solder Pad Design—2-Lead Gullwing                     | 13 |
| Solder Pad Layout—2-Lead Gullwing                     | 13 |
| Pin Out Diagram—Gullwing Form                         | 13 |
| Mechanical Dimensions—LUXEON K2 with TFFC Star        | 14 |
| Wavelength Characteristics                            | 15 |
| Typical Light Output Characteristics Over Temperature | 17 |
| Typical Forward Current Characteristics               | 20 |
| Typical Relative Luminous Flux                        | 20 |
| Current Derating Curves                               | 21 |
| Typical Radiation Patterns                            | 24 |
| Emitter Reel Packaging                                | 26 |
| Product Binning and Labeling                          | 27 |
| Luminous Flux Bins                                    | 28 |
| Forward Voltage Bins                                  | 29 |
| White Binning Information                             | 30 |
| LUXEON K2 with TFFC Cool-White Bin Structure          | 31 |
| LUXEON K2 with TFFC Neutral-White Bin Structure       | 33 |
| LUXEON K2 with TFFC Warm-White Bin Structure          | 35 |
| Color Bins  | 37 |

---

## Product Nomenclature

The LUXEON K2 with TFFC is tested and binned at 1000mA.

The part number designation is explained as follows:

L X K 2 - A B C D - E F G H for Emitter  
L 2 K 2 - A B C D - x x - E F G H for Star

Where:

A — designates radiation pattern (Value P for Lambertian emitter, M for Lambertian Star product)  
B — designates color (see Philips Lumileds AB21)  
C — designates color variant (1 for direct colors, C for Cool-White, N for Neutral-White, and W for Warm-White)  
D — designates test current (value 4 for 1000 mA)  
E — Reserved for future offerings  
FGH — minimum luminous flux (lm) or radiometric power (mW) performance

x x - indicates array description for Level 2 Star Product (11 for 1x1 array)

Therefore, products tested and binned at 1000mA follow the part numbering scheme:

L X K 2 - P x x 4 - x x x x (L 2 K 2 - P x x 4 - 1 1 - x x x x for TFFC Star)

## Average Lumen Maintenance Characteristics

Lifetime for solid-state lighting devices (LEDs) is typically defined in terms of lumen maintenance—the percentage of initial light output remaining after a specified period of time.

Philips Lumileds projects that white LUXEON K2 with TFFC products will deliver, on average, **TBD%** lumen maintenance at **TBD** hours of operation at a forward current of **TBD** mA. This projection is based on constant current operation with junction temperature maintained at or below **TBD**°C. Philips Lumileds projects that green, blue, cyan and royal blue LUXEON K2 with TFFC products will deliver, on average, **TBD%** lumen maintenance at **TBD** hours of operation at a forward current of **TBD** mA. This projection is based on constant current operation with junction temperature maintained at or below **TBD**°C.

This performance is based on independent test data, Philips Lumileds historical data from tests run on similar material systems, and internal LUXEON reliability testing. Observation of design limits included in this data sheet is required in order to achieve this projected lumen maintenance.

## Environmental Compliance

Philips Lumileds is committed to providing environmentally friendly products to the solid-state lighting market. The LUXEON K2 with TFFC is compliant to the European Union directives on the Restriction of Hazardous Substances in electronic equipment, namely the RoHS directive. Philips Lumileds will not intentionally add the following restricted materials to the LUXEON K2 with TFFC: lead, mercury, cadmium, hexavalent chromium, polybrominated biphenyls (PBB) or polybrominated diphenyl ethers (PBDE).

## Flux Characteristics for LUXEON K2 with TFFC Junction and Case Temperature = 25°C<sup>[5]</sup>

Table 1.

| Minimum Performance at Test Current |                |   | Typical Performance at Indicated Current                      |           |           |
|-------------------------------------|----------------|---|---|-----------|-----------|
| Color                               | Part Number    | Minimum Luminous Flux (lm) or Radiometric Power (mW) $\Phi_V$ | Typical Luminous Flux (lm) or Radiometric Power (mW) $\Phi_V$ |           |           |
|                                     |                | at 1000mA   | at 1500 mA  | at 700 mA | at 350 mA |
| Cool-White                          | LXK2-PWC4-0220 | 220   | 300   | 190       | 110       |
|                                     | LXK2-PWC4-0200 | 200   | 275   | 170       | 95        |
|                                     | LXK2-PWC4-0180 | 180   | 250   | 150       | 85        |
|                                     | LXK2-PWC4-0160 | 160   | 220   | 135       | 75        |
| Neutral-White                       | LXK2-PWN4-0200 | 200   | 275   | 170       | 95        |
|                                     | LXK2-PWN4-0180 | 180   | 250   | 150       | 85        |
|                                     | LXK2-PWN4-0160 | 160   | 220   | 135       | 75        |
|                                     | LXK2-PWN4-0140 | 140   | 195   | 120       | 65        |
| Warm-White                          | LXK2-PWW4-0160 | 160   | 220   | 135       | 75        |
|                                     | LXK2-PWW4-0140 | 140   | 195   | 120       | 65        |
|                                     | LXK2-PWW4-0120 | 120   | 170   | 105       | 55        |
| Green                               | LXK2-PM14-0200 | 200   | 275   | 170       | 95        |
|                                     | LXK2-PM14-0180 | 180   | 250   | 150       | 85        |
|                                     | LXK2-PM14-0160 | 160   | 220   | 135       | 75        |
|                                     | LXK2-PM14-0140 | 140   | 195   | 120       | 65        |
| Cyan                                | LXK2-PE14-0180 | 180   | 250   | 150       | 85        |
|                                     | LXK2-PE14-0160 | 160   | 220   | 135       | 75        |
|                                     | LXK2-PE14-0140 | 140   | 195   | 120       | 65        |
|                                     | LXK2-PE14-0120 | 120   | 170   | 105       | 55        |
| Blue                                | LXK2-PB14-0060 | 60  | 85  | 50        | 30        |
|                                     | LXK2-PB14-0050 | 50  | 75  | 40        | 25        |
|                                     | LXK2-PB14-0040 | 40  | 65  | 35        | 20        |
|                                     | LXK2-PB14-0030 | 30  | 45  | 25        | 15        |
| Royal Blue                          | LXK2-PR14-0600 | 600 mW  | 780   | 480       | 275       |
|                                     | LXK2-PR14-0700 | 700 mW  | 910   | 560       | 315       |

Notes for Table 1:

1. Minimum luminous flux or radiometric power performance guaranteed within published operating conditions. Philips Lumileds maintains a tolerance of  $\pm 10\%$  on flux and power measurements of LUXEON K2 with TFFC.
2. Typical luminous flux or radiometric power performance when device is operated within published operating conditions.
3. LUXEON K2 with TFFC products with even higher luminous flux and radiometric power levels will become available in the future. Please consult Philips Lumileds or Future Electronics for more information.
4. Radiation Pattern for all LUXEON K2 with TFFC products is Lambertian.
5. LUXEON K2 with TFFC is tested and binned at 25°C with a 20ms monopulse test to avoid heating of the junction or case.
6. For Red, Red-Orange, and Amber products, please see LUXEON K2 datasheet, DS51.

## Flux Characteristics for LUXEON K2 with TFFC Star Junction and Case Temperature = 25°C<sup>[5]</sup>

Table 2.

| Minimum Performance at Test Currents |                   |  | Typical Performance at Indicated Current                         |           |           |
|--------------------------------------|-------------------|--|--|-----------|-----------|
| Color                                | Part Number       | Minimum Luminous Flux (lm) or<br>Radiometric Power (mW) $\Phi_V$ | Typical Luminous Flux (lm) or<br>Radiometric Power (mW) $\Phi_V$ |           |           |
|                                      |                   | at 1000mA  | at 1500 mA   | at 700 mA | at 350 mA |
| Cool-<br>White                       | L2K2-MWC4-11-0220 | 220  | 300  | 190       | 110       |
|                                      | L2K2-MWC4-11-0200 | 200  | 275  | 170       | 95        |
|                                      | L2K2-MWC4-11-0180 | 180  | 250  | 150       | 85        |
|                                      | L2K2-MWC4-11-0160 | 160  | 220  | 135       | 75        |
| Neutral-<br>White                    | L2K2-MWN4-11-0200 | 200  | 275  | 170       | 95        |
|                                      | L2K2-MWN4-11-0180 | 180  | 250  | 150       | 85        |
|                                      | L2K2-MWN4-11-0160 | 160  | 220  | 135       | 75        |
|                                      | L2K2-MWN4-11-0140 | 140  | 195  | 120       | 65        |
| Warm-<br>White                       | L2K2-MWW4-11-0160 | 160  | 220  | 135       | 75        |
|                                      | L2K2-MWW4-11-0140 | 140  | 195  | 120       | 65        |
|                                      | L2K2-MWW4-11-0120 | 120  | 170  | 105       | 55        |

Notes for Table 2:

1. Minimum luminous flux or radiometric power performance guaranteed within published operating conditions. Philips Lumileds maintains a tolerance of  $\pm 10\%$  on flux and power measurements of LUXEON K2 with TFFC.
2. Typical luminous flux or radiometric power performance when device is operated within published operating conditions.
3. LUXEON K2 with TFFC products with even higher luminous flux and radiometric power levels will become available in the future. Please consult Philips Lumileds or Future Electronics for more information.
4. Radiation Pattern for all LUXEON K2 with TFFC products is Lambertian.
5. Luxeon K2 with TFFC is tested and binned at 25°C with a 20ms monopulse test to avoid heating of the junction or case.

## Optical Characteristics

### LUXEON K2 with TFFC at Test Current<sup>[1]</sup> Junction and Case Temperature = 25°C<sup>[11]</sup>

Table 3.

| Color                     | Dominant Wavelength <sup>[2]</sup> $\lambda_D$ ,<br>Peak Wavelength <sup>[3]</sup> $\lambda_P$ ,<br>or Color Temperature <sup>[4]</sup><br>CCT |        |         | Typical<br>Spectral<br>Half-width <sup>[6]</sup><br>(nm)<br>$\Delta\lambda_{1/2}$ | Typical<br>Temperature<br>Coefficient of<br>Dominant<br>Wavelength<br>(nm/°C)<br>$\Delta\lambda_D / \Delta T_J$ | Typical<br>Total<br>Included<br>Angle <sup>[7]</sup><br>(degrees)<br>$\theta_{0.90V}$ | Typical<br>Viewing<br>Angle <sup>[8]</sup><br>(degrees)<br>$2\theta_{1/2}$ |
|---------------------------|--|--------|---------|---|---|---|--|
|                           | Min.   | Typ.   | Max.    |   |   |   |  |
| Cool White                | 4500 K   | 6500 K | 10000 K | -   | -   | 160   | 120  |
| Neutral White             | 3500K  | 4100K  | 4500K   | -   | -   | 160   | 120  |
| Warm White                | 2670K  | 3000K  | 3500K   | -   | -   | 160   | 120  |
| Green                     | 520 nm   | 530 nm | 550 nm  | 35  | 0.04  | 160   | 120  |
| Cyan                      | 490 nm   | 505 nm | 520 nm  | 30  | 0.04  | 160   | 120  |
| Blue                      | 460 nm   | 470 nm | 490 nm  | 25  | 0.04  | 160   | 120  |
| Royal Blue <sup>[9]</sup> | 440 nm   | 455 nm | 460 nm  | 20  | 0.04  | 160   | 120  |

Notes for Table 3:

1. Test current is 1000 mA for all LXXK2 - xxx4 - xxxx products (L2K2 - xxx4 - 11 - xxxx for TFFC Star).
2. Dominant wavelength is derived from the CIE 1931 Chromaticity diagram and represents the perceived color. Philips Lumileds maintains a tolerance of  $\pm 0.5$  nm for dominant wavelength measurements.
3. Royal blue product is binned by radiometric power and peak wavelength rather than photometric lumens and dominant wavelength. Philips Lumileds maintains a tolerance of  $\pm 2$  nm for peak wavelength measurements.
4. CCT  $\pm 5\%$  tester tolerance
5. Typical CRI (Color Rendering Index) for Cool-White product is 70, Neutral-White is 75, and Warm-White is 80.
6. Spectral width at  $1/2$  of the peak intensity.
7. Total angle at which 90% of total luminous flux is captured.
8. Viewing angle is the off axis angle from lamp centerline where the luminous intensity is  $1/2$  of the peak value.
9. All white, green, cyan, blue and royal blue products are built with Indium Gallium Nitride (InGaN).
10. White, Blue, and Royal Blue power light sources represented here are IEC60825 class 2 for eye safety.
11. Luxeon K2 with TFFC is tested and binned at 25°C with a 20ms monopulse test to avoid heating of the junction or case.

## Electrical Characteristics

### Electrical Characteristics at 1000mA Part Numbers L XK2-xxx4-xxx, Junction and Case Temperature = 25°C<sup>[4]</sup>

Table 4.

| Color                        | Forward Voltage $V_f$ <sup>[1]</sup> (V) |      |      | Typical Dynamic Resistance <sup>[2]</sup> ( $\Omega$ )<br>$R_D$ | Typical Temperature Coefficient of Forward Voltage (mV/°C)<br>$\Delta V_F / \Delta T_J$ | Typical Thermal Resistance Junction to Case (°C/W)<br>$R\theta_{JC}$ |
|------------------------------|--|------|------|---|---|--|
|                              | Min.                                     | Typ. | Max. |   |   |  |
| Cool-White <sup>[3]</sup>    | 3.03                                     | 3.72 | 4.95 | 0.45  | -2.8  | 7 (11 for Star)  |
| Neutral-White <sup>[3]</sup> | 3.03                                     | 3.72 | 4.95 | 0.45  | -2.8  | 7 (11 for Star)  |
| Warm-White <sup>[3]</sup>    | 3.03                                     | 3.72 | 4.95 | 0.45  | -2.8  | 7 (11 for Star)  |
| Green <sup>[3]</sup>         | 3.03                                     | 3.72 | 4.95 | 0.45  | TBD   | 7  |
| Cyan <sup>[3]</sup>          | 3.03                                     | 3.72 | 4.95 | 0.45  | TBD   | 7  |
| Blue <sup>[3]</sup>          | 3.03                                     | 3.72 | 4.95 | 0.45  | TBD   | 7  |
| Royal Blue <sup>[3]</sup>    | 3.03                                     | 3.72 | 4.95 | 0.45  | TBD   | 7  |

Notes for Table 4:

1. Philips Lumileds maintains a tolerance of  $\pm 0.06V$  on forward voltage measurements
2. Dynamic resistance is the inverse of the slope in linear forward voltage model for LEDs. See figure 13.
3. The forward voltage of the LUXEON K2 with TFFC LED will reduce by up to 0.50V at 1000mA during the first few hours of operation after SMT reflow. Due to this effect, Philips Lumileds recommends current source drive for consistent and reliable performance. Cross connected series/parallel arrays or voltage drivers which could result in current hogging or variation in drive current are not recommended. Please consult your Philips Lumileds authorized distributor or Philips Lumileds Sales Representative for further information.
4. Luxeon K2 with TFFC is tested and binned at 25°C with a 20ms monopulse test to avoid heating of the junction or case.

### Typical Electrical Characteristics Part Numbers L XK2-xxx4-xxx, Junction and Case Temperature = 25°C

Table 5.

| Color         | Typical Forward Voltage $V_f$ (V) |          |          |
|---------------|-----------------------------------|----------|----------|
|               | at 1500mA                         | at 700mA | at 350mA |
| Cool-White    | 3.85                              | 3.6      | 3.42     |
| Neutral-White | 3.85                              | 3.6      | 3.42     |
| Warm-White    | 3.85                              | 3.6      | 3.42     |
| Green         | 3.85                              | 3.6      | 3.42     |
| Cyan          | 3.85                              | 3.6      | 3.42     |
| Blue          | 3.85                              | 3.6      | 3.42     |
| Royal Blue    | 3.85                              | 3.6      | 3.42     |

## Absolute Maximum Ratings<sup>[3]</sup>

Table 6.

| Parameter                               | Cool-White/Neutral-White/<br>Warm-White<br>Value | Green/Cyan<br>Blue/Royal Blue<br>Value      |
|---|--|---|
| DC Forward Current (mA)                 | 1500   | 1500  |
| Peak Pulsed Forward Current (mA)        | 1500   | 1500  |
| Average Forward Current (mA)            | 1500   | 1500  |
| ESD Sensitivity                         | > 2,000 V HBM<br>Class 2 JESD22-A114-B           | > 2,000 V HBM<br>Class 2 JESD22-A114-B      |
| LED Junction Temperature <sup>[1]</sup> | 150°C  | 185°C                                       |
| Storage Temperature                     | -40°C - 185°C                                    | -40°C - 185°C                               |
| Soldering Temperature                   | JEDEC 020c 260°C                                 | JEDEC 020c 260°C                            |
| Allowable Reflow Cycles                 | 3  | 3   |
| Autoclave Conditions                    | 121°C at 2 ATM,<br>100% RH for 72 hours max      | 121°C at 2 ATM,<br>100% RH for 72 hours max |
| Reverse Voltage (Vr)                    | See Note 2                                       | See Note 2                                  |

Notes for Table 6:

1. Proper current derating must be observed to maintain junction temperature below the maximum.
2. LEDs are not designed to be driven in reverse bias.
3. Stresses in excess of the absolute maximum ratings can cause damage to the emitter. Maximum Rating limits apply to each parameter in isolation, all parameters having values within the Current Derating Curve. It should not be assumed that limiting values of more than one parameter can be applied to the product at the same time. Exposures to the absolute maximum ratings for extended periods can adversely affect device reliability. See Allowable Use Condition profiles below.

# JEDEC Moisture Sensitivity

Table 7.

| Level | Soak Requirements |                 |                           |               |                         |               |
|-------|-------------------|-----------------|---------------------------|---------------|-------------------------|---------------|
|       | Floor Life        |                 | Standard                  |               | Accelerated Environment |               |
|       | Time              | Conditions      | Time (hours)              | Conditions    | Time (hours)            | Conditions    |
| 2a    | 4 weeks           | ≤ 30°C / 60% RH | 696 <sup>(1)</sup> + 5/-0 | 30°C / 60% RH | 120 +1/-0               | 60°C / 60% RH |

Notes for Table 7:

- The standard soak time includes a default value of 24 hours for semiconductor manufacturer's exposure time (MET) between bake and bag and includes the maximum time allowed out of the bag at the distributor's facility.

## Reflow Soldering Characteristics<sup>[1]</sup>

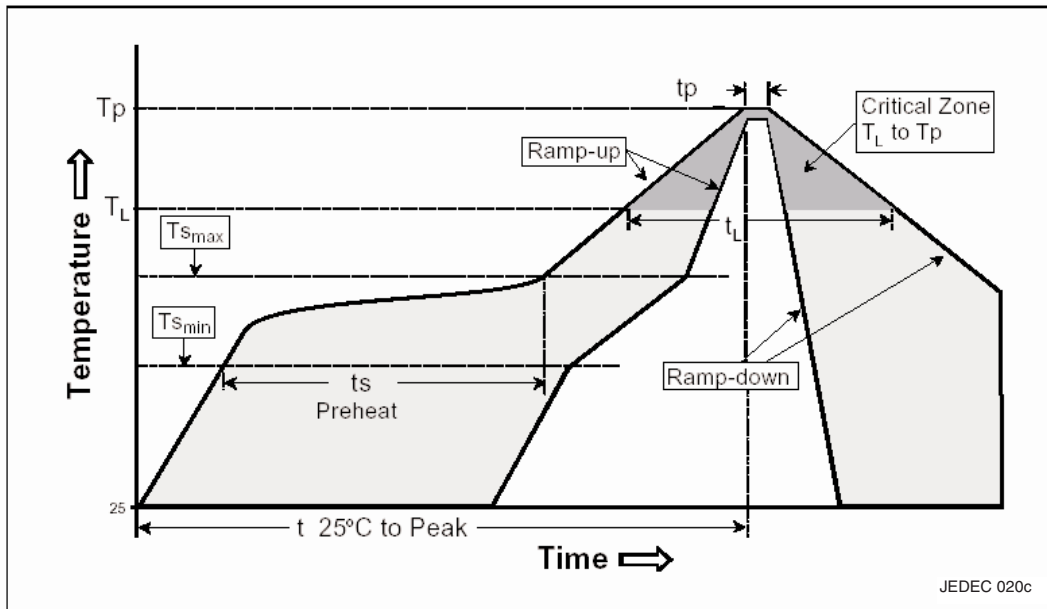

Table 8.

| Profile Feature                                      | Lead Free Assembly |
|--|--------------------|
| Average Ramp-Up Rate ( $T_{s_{max}}$ to $T_p$ )      | 3°C / second max   |
| Preheat Temperature Min ( $T_{s_{min}}$ )            | 150°C              |
| Preheat Temperature Max ( $T_{s_{max}}$ )            | 200°C              |
| Preheat Time ( $t_{s_{min}}$ to $t_{s_{max}}$ )      | 60 - 180 seconds   |
| Temperature ( $T_l$ )                                | 217°C              |
| Time Maintained Above Temperature ( $T_l$ )          | 60 - 150 seconds   |
| Peak / Classification Temperature ( $T_p$ )          | 260°C              |
| Time Within 5°C of Actual Peak Temperature ( $T_p$ ) | 20 - 40 seconds    |
| Ramp - Down Rate                                     | 6°C / second max   |
| Time 25°C to Peak Temperature                        | 8 minutes max      |

Notes for Table 8:

- All temperatures refer to topside of the package, measured on the package body surface.

## Mechanical Dimensions—SMT 4-Lead Gullwing Form

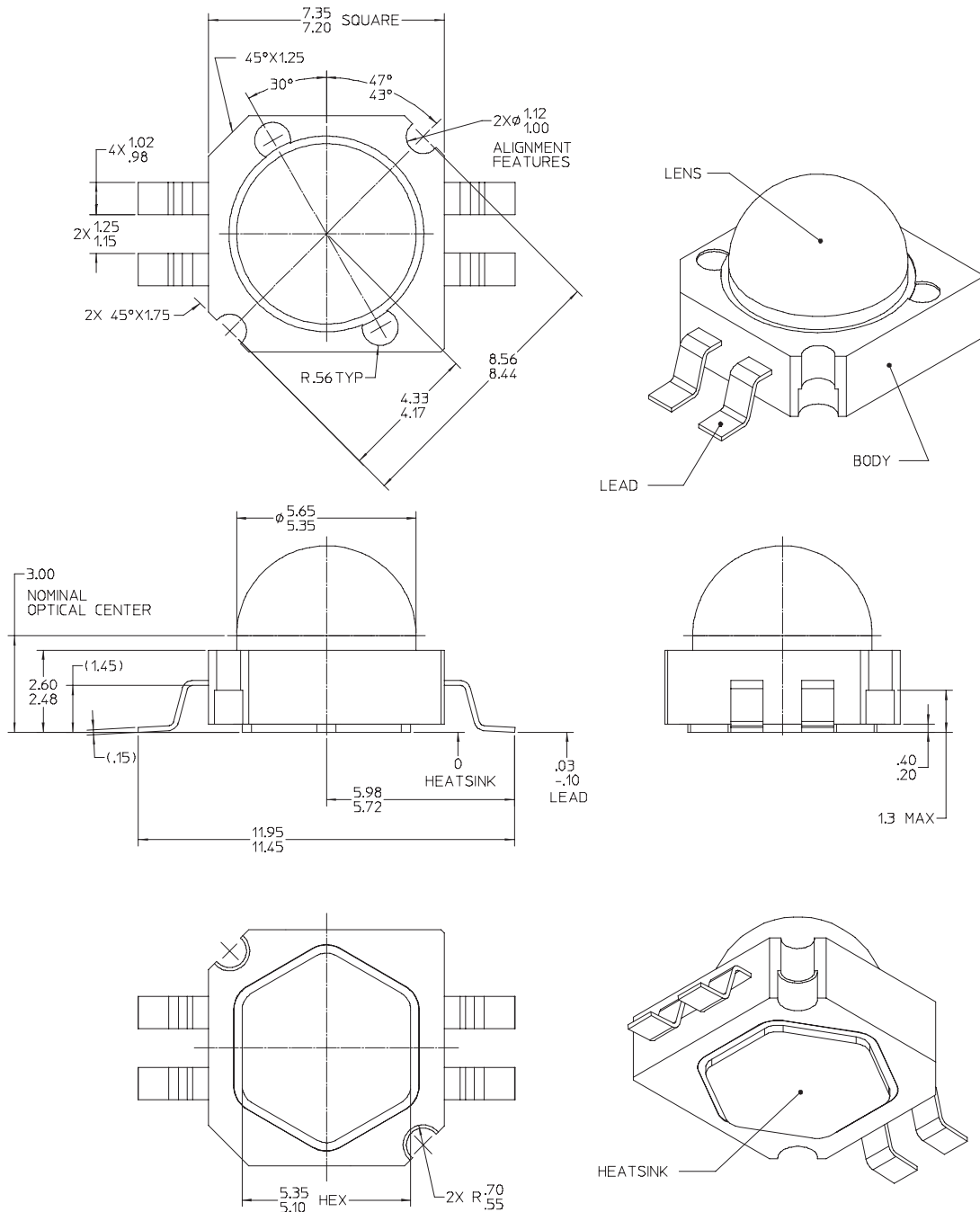

Figure 1. 4-lead Gullwing Package Outline Drawing.

Notes for Figure 1:

1. The anode side of the device is denoted by the chamfer on the part body. Electrical insulation between the case and the board is required—slug of the device is not electrically neutral. Do not electrically connect either the anode or cathode to the slug.
2. Do not handle the device by the lens except as described in Philips Lumileds document AB29.
3. Drawings not to scale.
4. All dimensions are in millimeters.
5. All dimensions without tolerances are for reference only.
6. Recommended solder paste thickness of 0.15mm.

## Solder Pad Design—SMT Lead Form

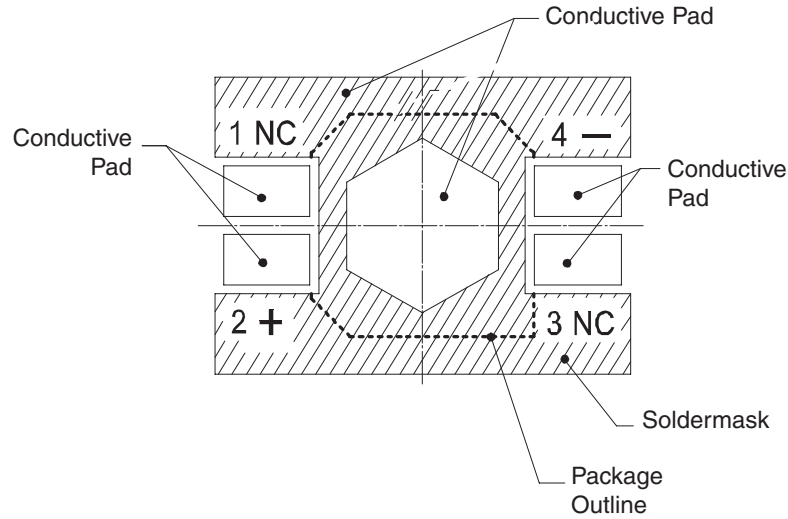

Figure 2. 4-Lead Gullwing Solder Pad Design.

Notes for Figure 2:

1. Electrical isolation is required between signal leads and hexagonal heat slug contact.
2. For optimal thermal performance, maximize board metallization at hexagonal heat slug contact.

## Solder Pad Layout—SMT Lead Form

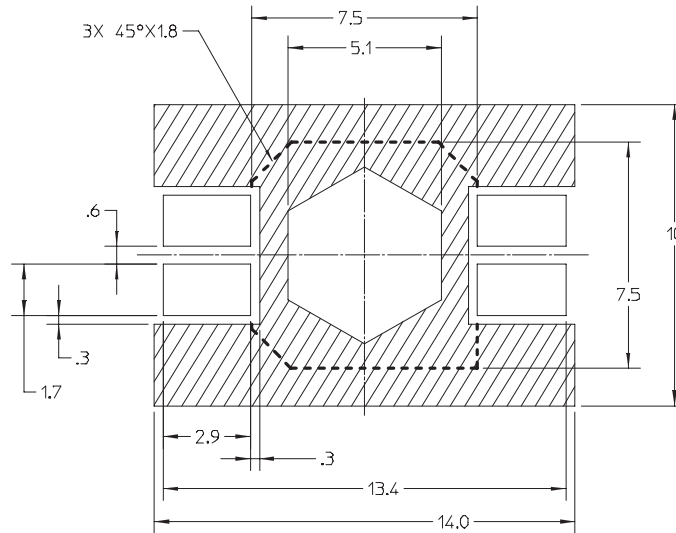

Figure 3. 4-Lead Gullwing Package Solder Pad Layout.

## Pin Out Diagram

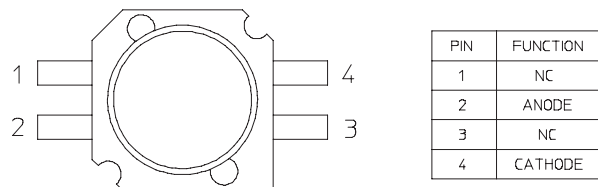
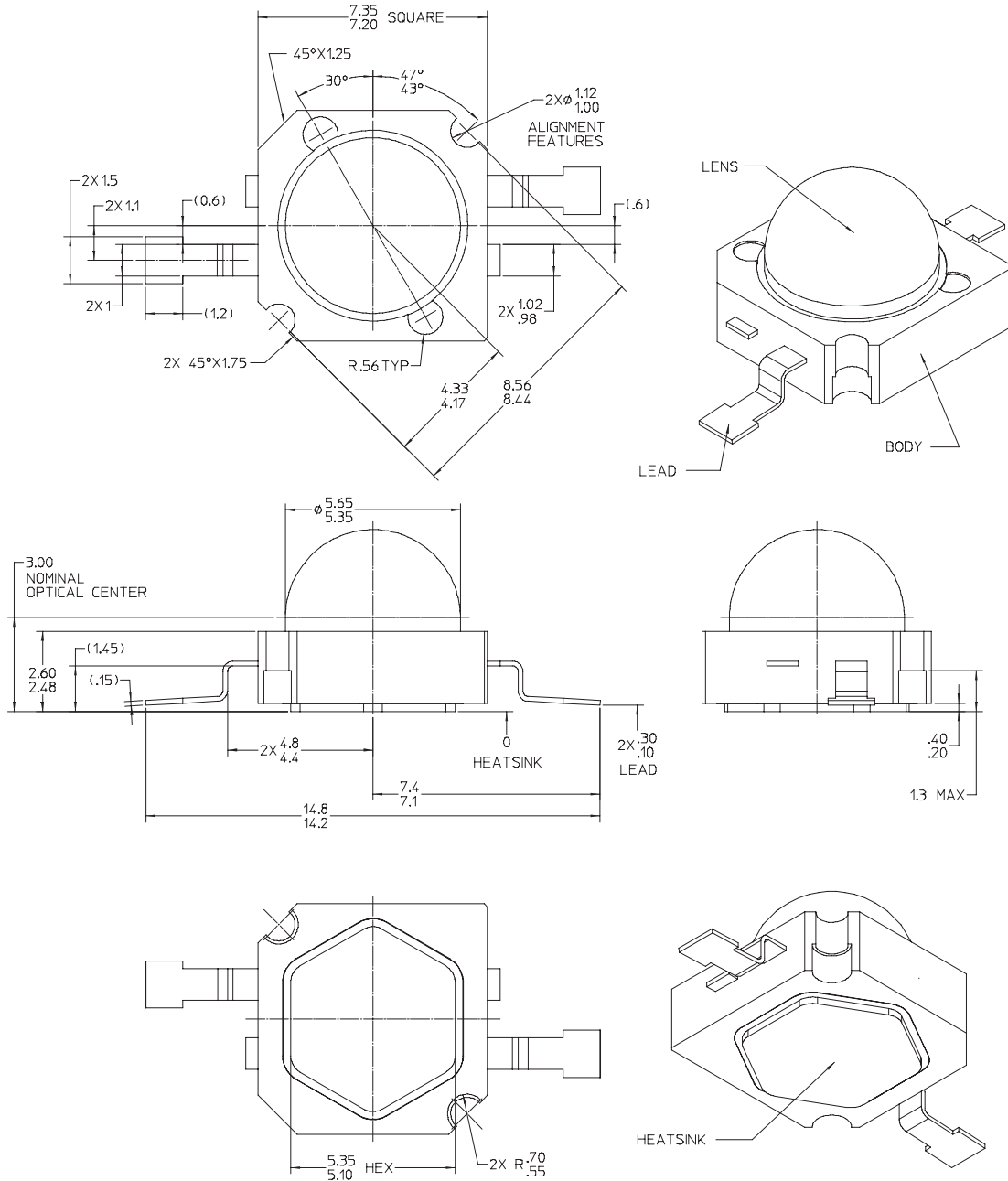

Figure 4. 4-Lead Gullwing Pin Out Diagram.

## Mechanical Dimensions—2-Lead Gullwing Form<sup>[8]</sup>



**Figure 5. 2-Lead Gullwing Package Outline Drawing.**

Notes for Figure 5:

1. The anode side of the device is denoted by the chamfer on the part body. Electrical insulation between the case and the board is required—slug of the device is not electrically neutral. Do not electrically connect either the anode or cathode to the slug.
2. Do not handle the device by the lens except as described in Philips Lumileds document AB29—care must be taken to avoid damage to the lens or the interior of the device that can be damaged by excessive force to the lens.
3. Drawings not to scale.
4. All dimensions are in millimeters.
5. All dimensions without tolerances are for reference only.
6. Recommended solder paste thickness of 0.15mm.
7. Available as a custom part number, contact your local sales representative for more information.
8. The 2-Lead Gullwing part is not recommended for use in solder re-flow systems. Mount these parts with a thermal adhesive and hot bar soldering. For conventional reflow surface-mounting, use 4-Lead Gullwing Form.

## Solder Pad Design—2-Lead Gullwing

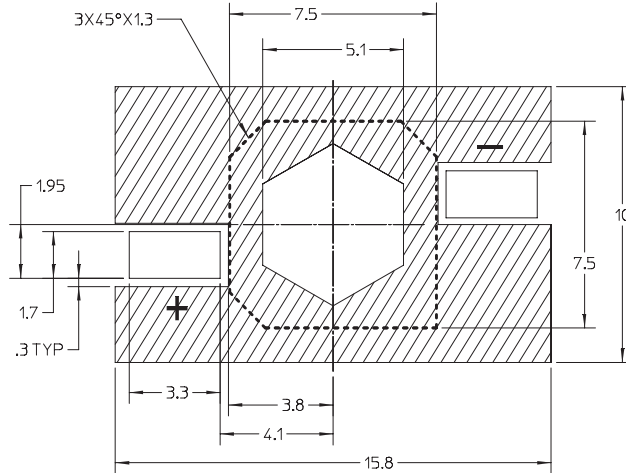

Figure 6. 2-Lead Gullwing Package Solder Pad Layout.

Notes for Figure 6:

1. Electrical isolation is required between signal leads and hexagonal heat slug contact.
2. For optimal thermal performance, maximize board metallization at hexagonal heat slug contact.

## Solder Pad Layout—2-Lead Gullwing

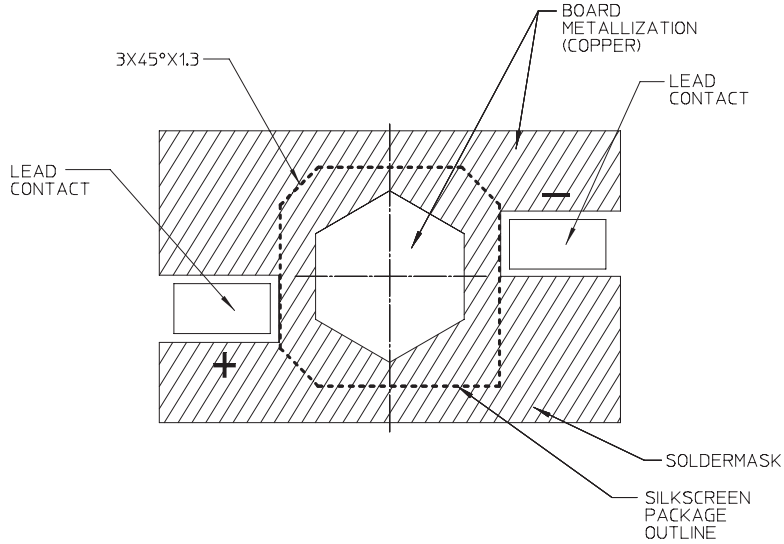
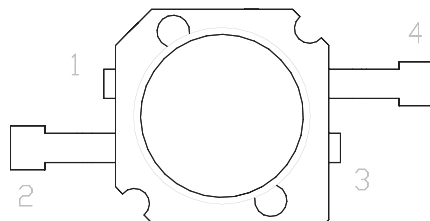

Figure 7. Solder Pad Layout 2-Lead Gullwing.

## Pin Out Diagram—Gullwing Form

PIN-OUT DETAIL



| PIN | FUNCTION     |
|-----|--------------|
| 1   | NC (TRIMMED) |
| 2   | ANODE        |
| 3   | NC (TRIMMED) |
| 4   | CATHODE      |

Figure 8. 2-Lead Gullwing Pin Out Diagram.

## Mechanical Dimensions— LUXEON K2 with TFFC Star

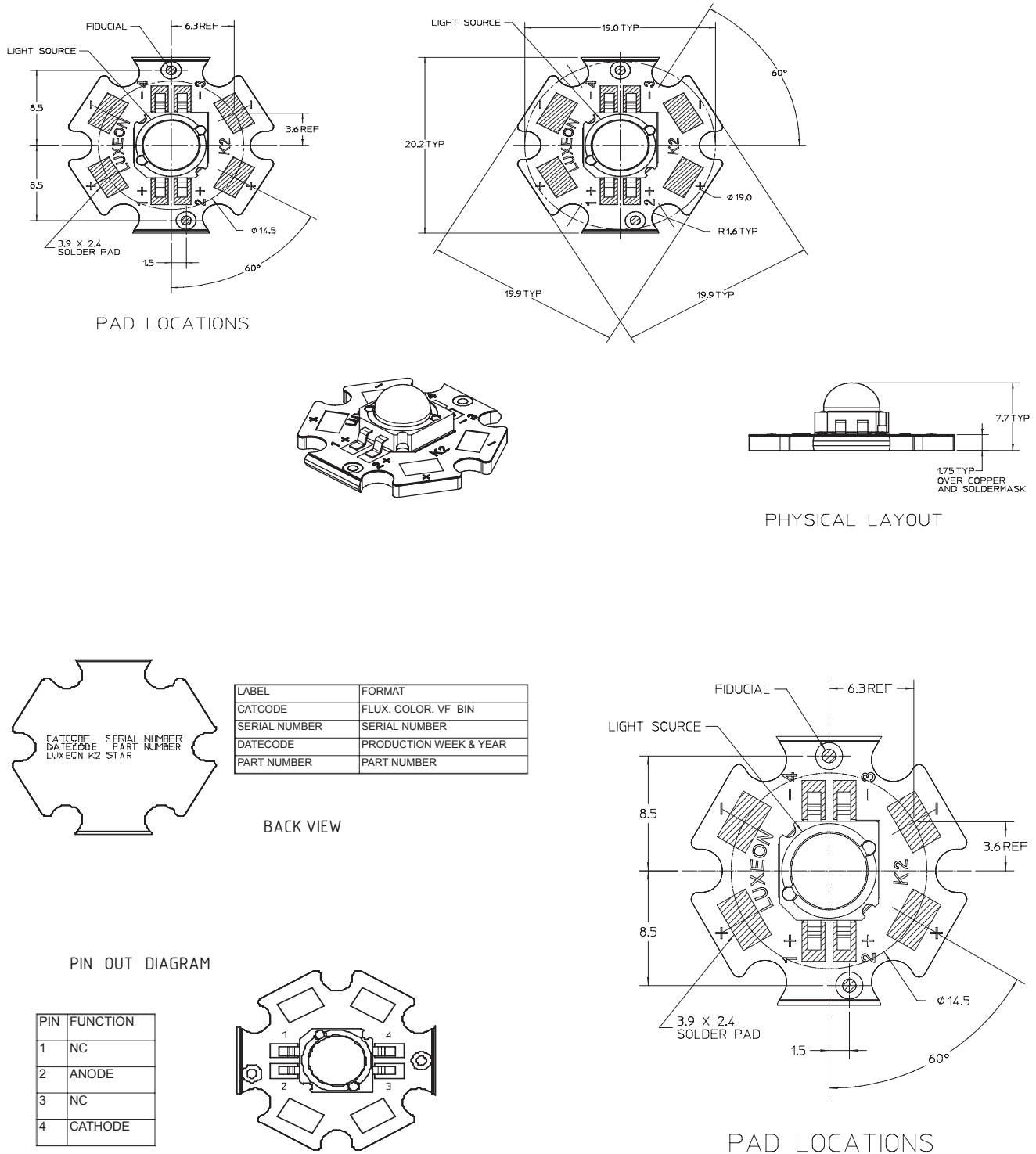

Figure 9. TFFC Star Package Outline Drawing.

Notes for Figure 9:

1. Slots in aluminum core PCB for M3 or #4 mounting screw.
2. Electrical interconnection pads labeled on the aluminum core PCB with "+" and "-" to denote positive and negative, respectively. All positive pads are interconnected, as are all negative pads, allowing for flexibility in array interconnection.
3. Drawings not to scale.
4. All dimensions are in millimeters.

## Wavelength Characteristics

### Green, Cyan, Blue and Royal Blue at Test Current Junction and Case Temperature = 25°C

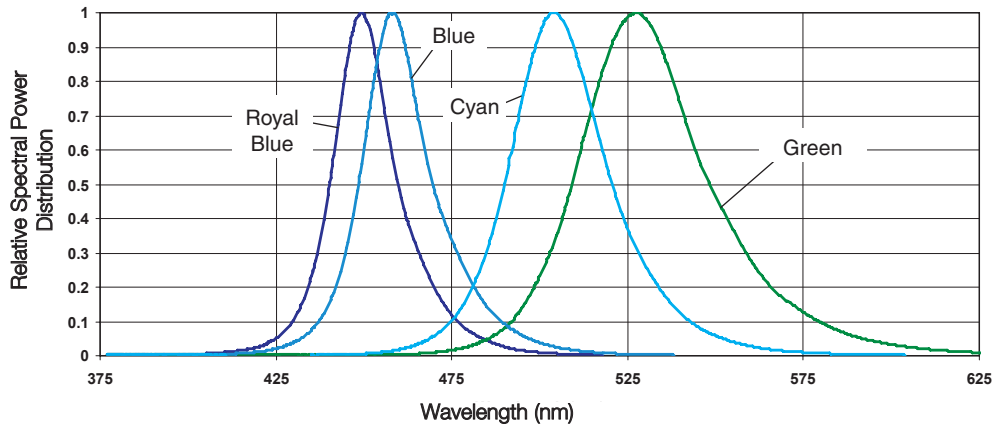

Figure 10. Relative intensity vs. wavelength.

### Cool-White at Test Current Junction and Case Temperature = 25°C

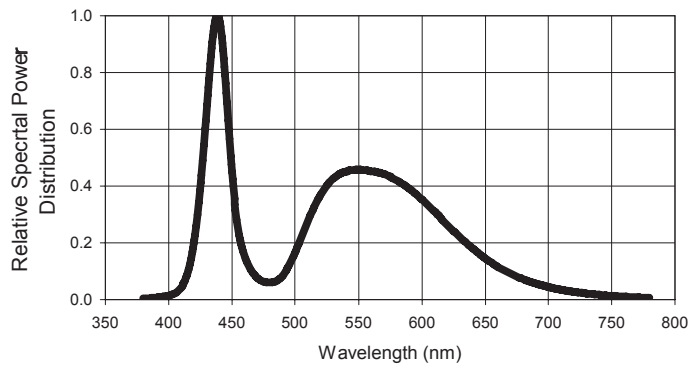

Figure 11a. Cool-White color spectrum of typical CCT part, integrated measurement.

## Wavelength Characteristics, Continued

### Neutral-White at Test Current Junction and Case Temperature = 25°C

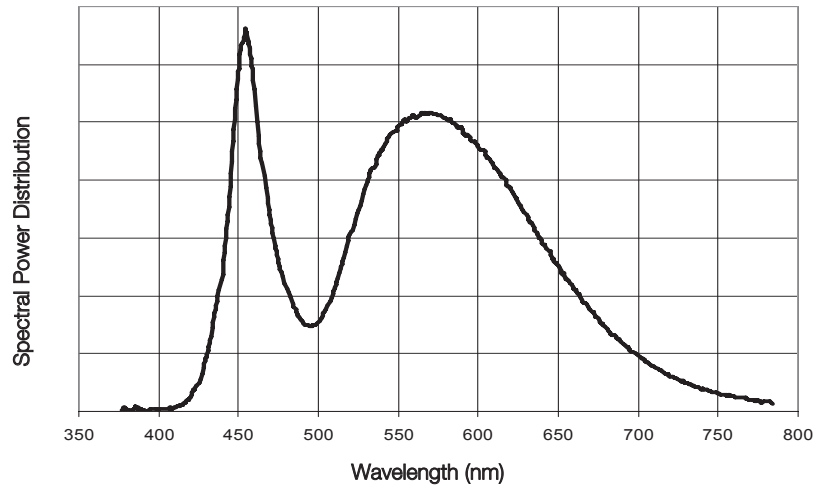

Figure 11b. Neutral-White color spectrum of typical CCT part, integrated measurement.

### Warm-White at Test Current Junction and Case Temperature = 25°C

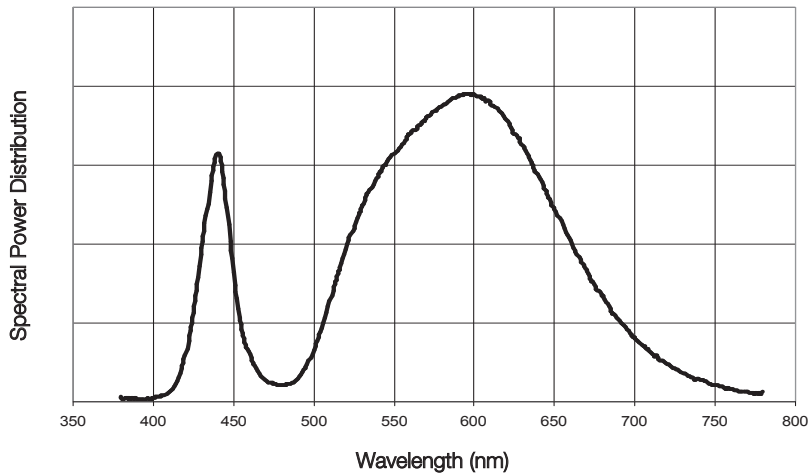

Figure 11c. Warm-White color spectrum of typical CCT part, integrated measurement.

# Typical Light Output Characteristics Over Temperature

Cool-White, Neutral-White and Warm-White at Test Current

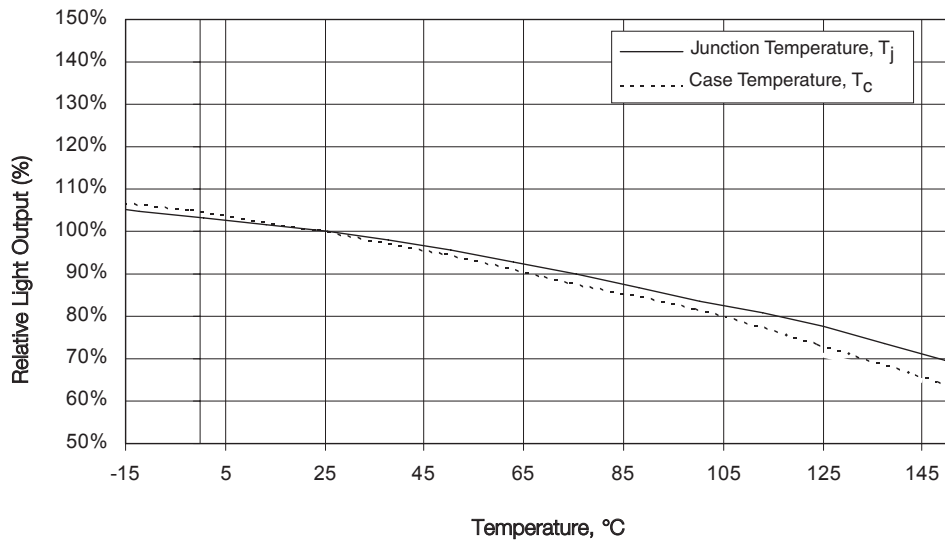

Figure 12a. Relative light output vs. temperature for white

Green at Test Current

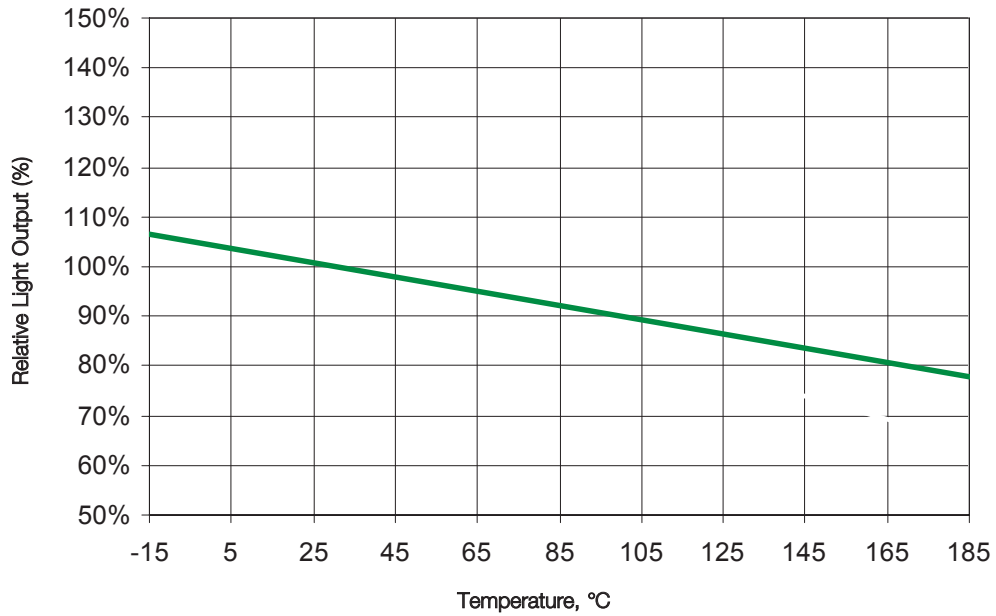

Figure 12b. Relative light output vs. junction temperature for green.

# Typical Light Output Characteristics Over Temperature, Continued

## Cyan at Test Current

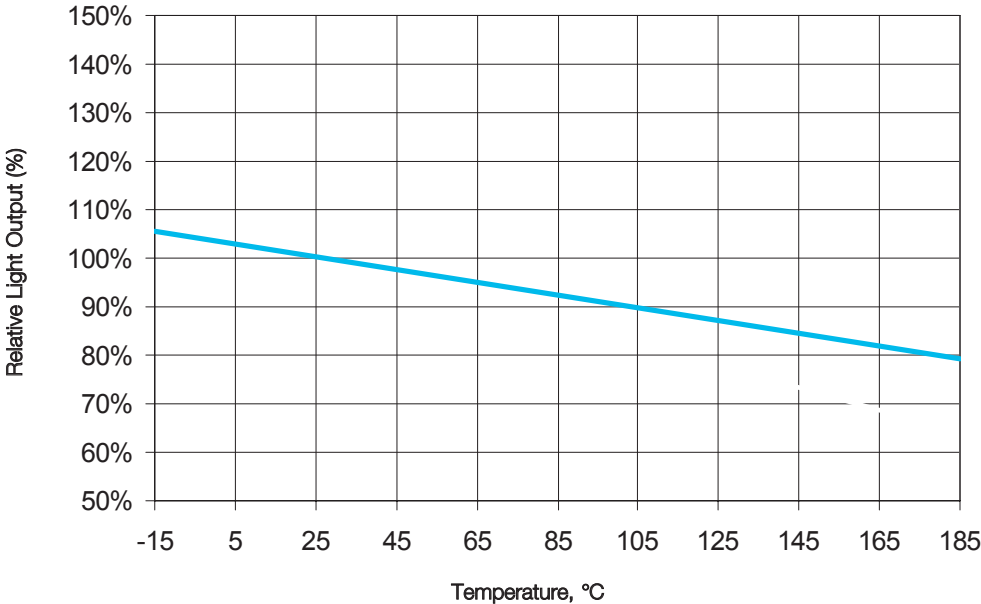

Figure 12c. Relative light output vs. junction temperature for cyan.

## Blue at Test Current

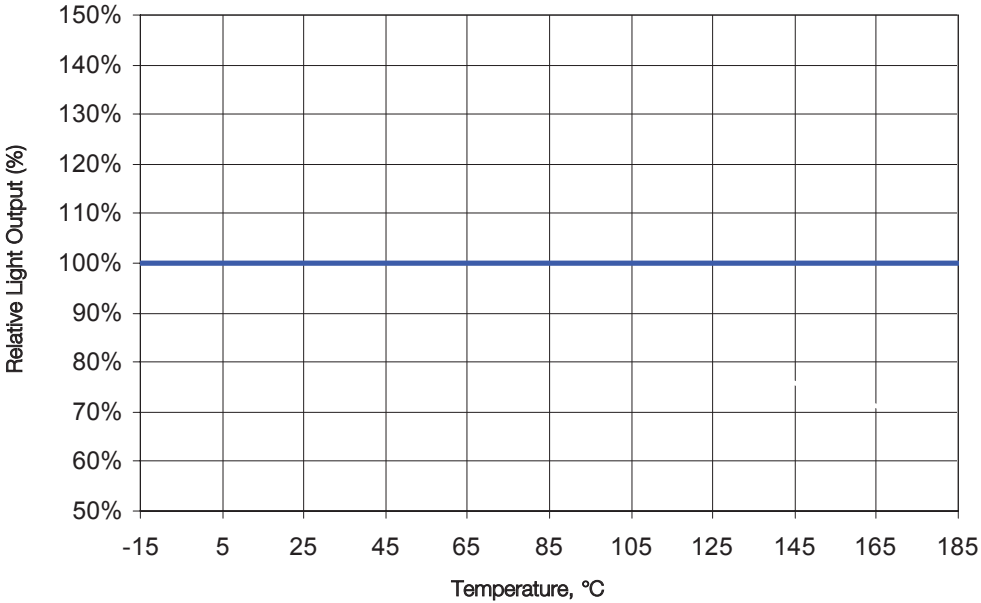

Figure 12d. Relative light output vs. junction temperature for blue.

# Typical Light Output Characteristics Over Temperature, Continued

## Royal Blue at Test Current

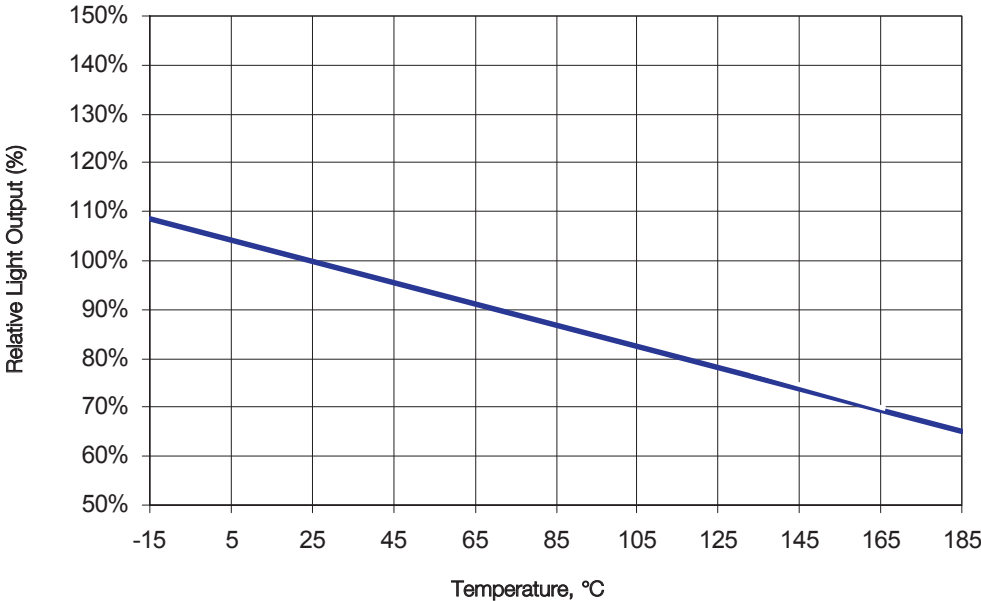

Figure 12e. Relative light output vs. junction temperature for royal blue.

## Typical Forward Current Characteristics

### Junction and Case Temperature = 25°C

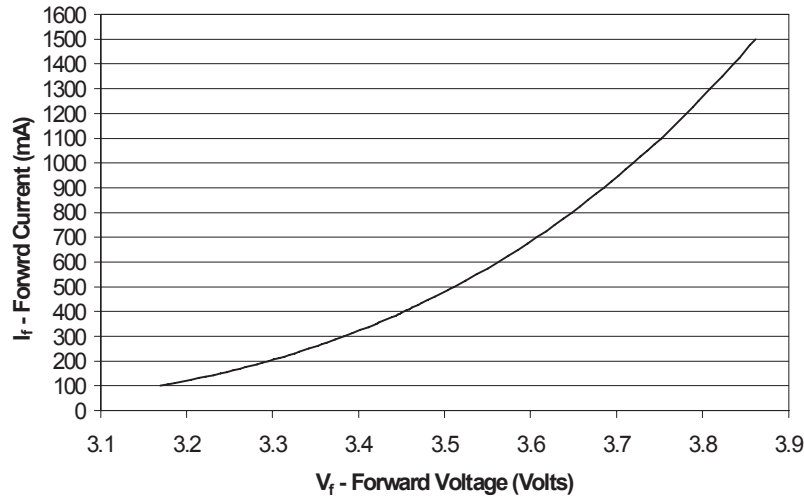

Figure 13. Forward current vs. forward voltage for white, green, cyan, blue and royal blue.

Notes for Figure 13:

1. Driving these high power devices at currents less than the test condition (1000 mA) may produce unpredictable results and may be subject to variation in performance. Pulse width modulation (PWM) is recommended for dimming effects.
2. Luxeon K2 with TFFC is tested and binned at 25°C with a 20ms monopulse test to avoid heating of the junction or case.

## Typical Relative Luminous Flux

### Relative Luminous Flux vs. Forward Current Junction and Case Temperature = 25°C

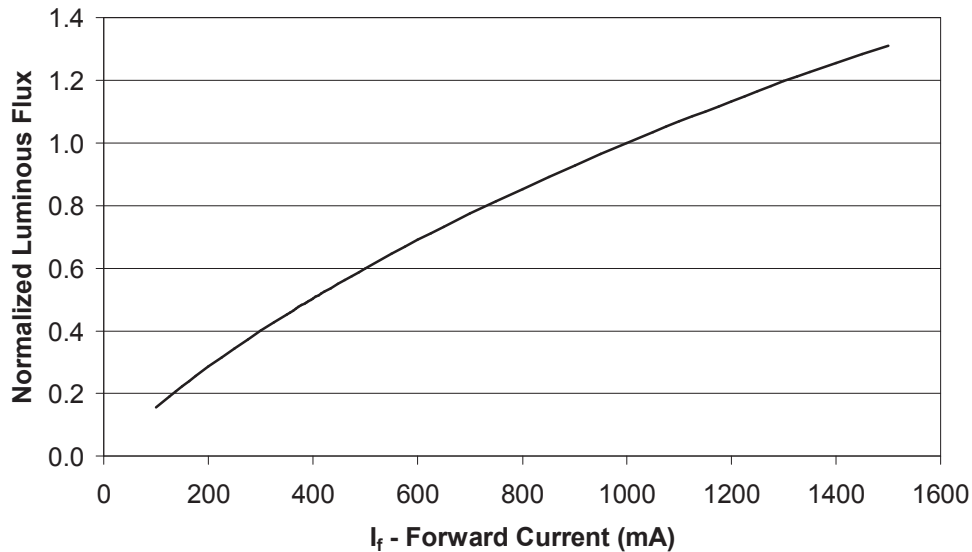

Figure 14. Relative luminous flux or radiometric power vs. forward current for white, green, cyan, blue and royal blue at 20ms monopulse, test current 1000 mA.

Notes for Figure 14:

1. Driving these high power devices at currents less than the test condition (1000 mA) may produce unpredictable results and may be subject to variation in performance. Pulse width modulation (PWM) is recommended for dimming effects.
2. Luxeon K2 with TFFC is tested and binned at 25°C with a 20ms monopulse test to avoid heating of the junction or case.

## Current Derating Curves

### Current Derating Curve for 350 mA Drive Current Cool-White, Neutral-White, Warm-White

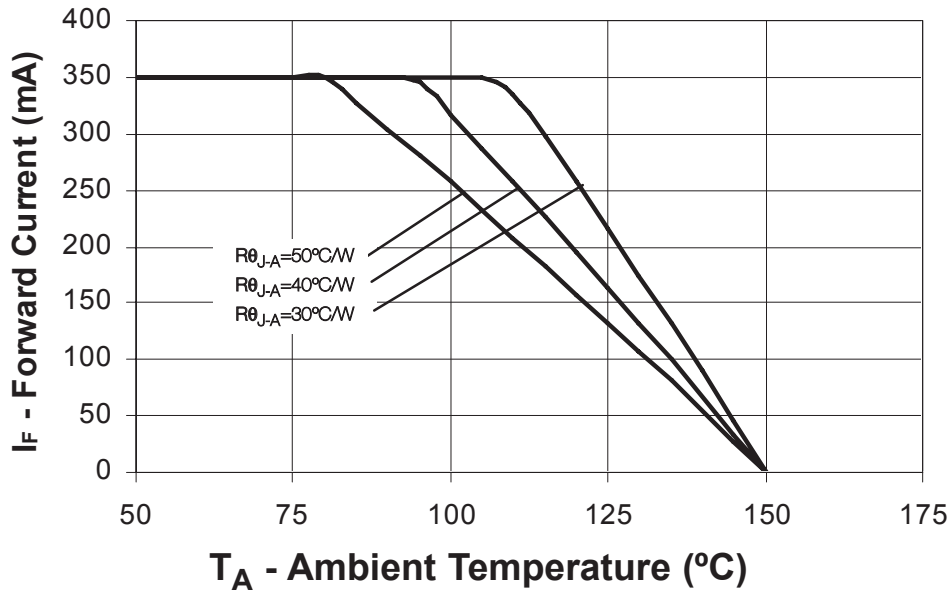

Figure 15: Maximum forward current vs. ambient temperature, based on  $T_{JMAX} = 150^\circ\text{C}$ .

### Current Derating Curve for 350 mA Drive Current Green, Cyan, Blue and Royal Blue

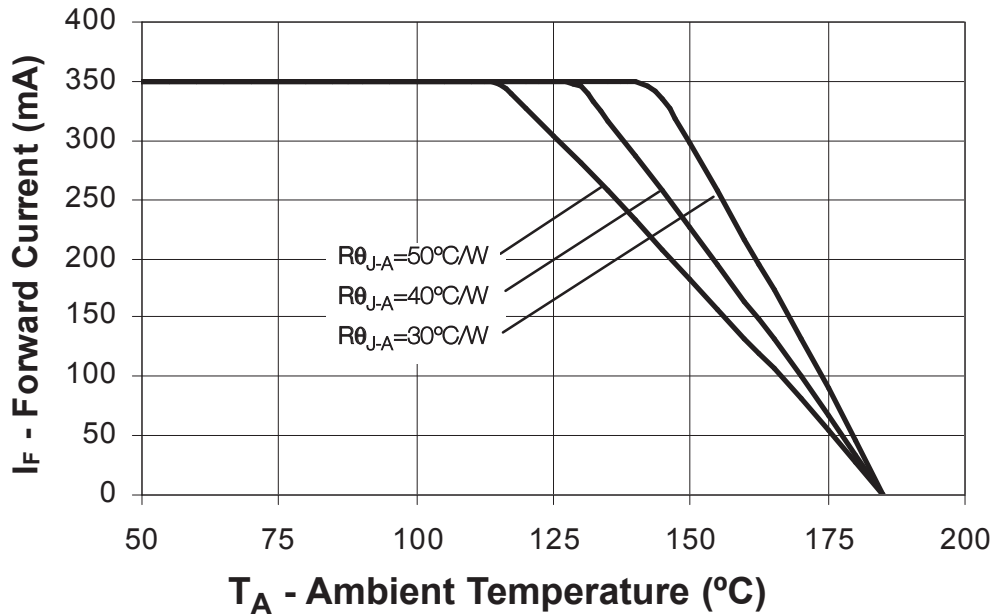

Figure 16: Maximum forward current vs. ambient temperature, based on  $T_{JMAX} = 185^\circ\text{C}$ .

### Current Derating Curve for 700 mA Drive Current Cool-White, Neutral-White, Warm-White

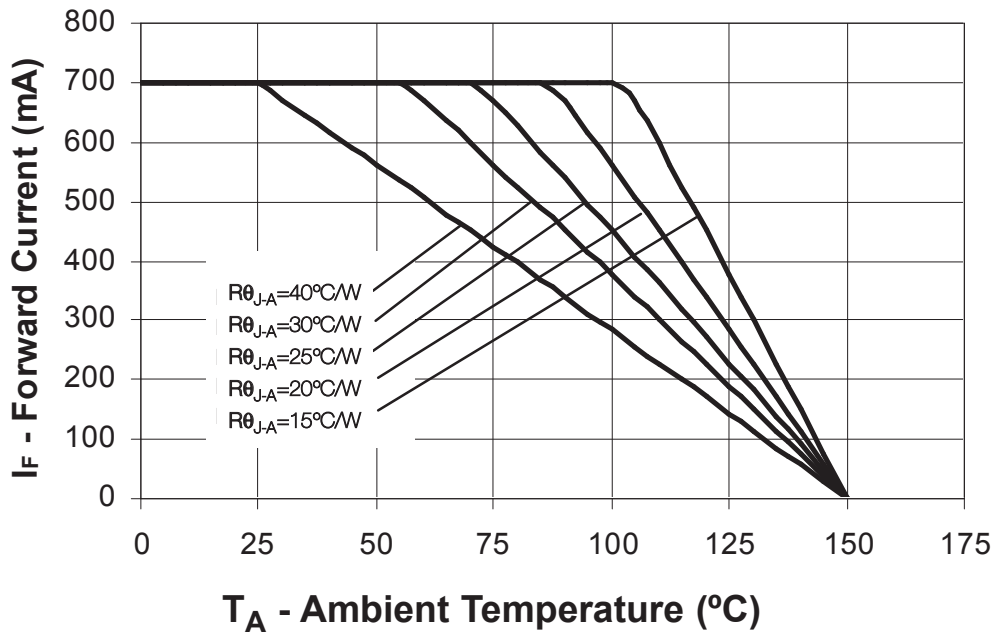

Figure 17: Maximum forward current vs. ambient temperature, based on  $T_{JMAX} = 150^\circ\text{C}$ .

### Current Derating Curve for 700 mA Drive Current Green, Cyan, Blue and Royal Blue

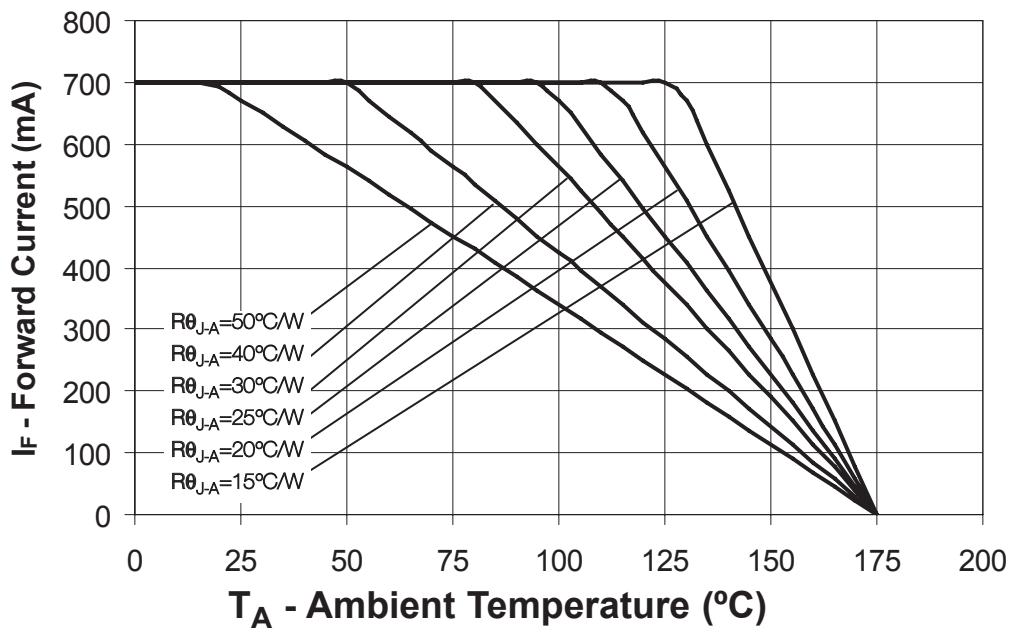

Figure 18: Maximum forward current vs. ambient temperature, based on  $T_{JMAX} = 175^\circ\text{C}$ .

## Current Derating Curve for 1000 mA Drive Current Cool-White, Neutral-White, Warm-White, Green, Cyan, Blue and Royal Blue

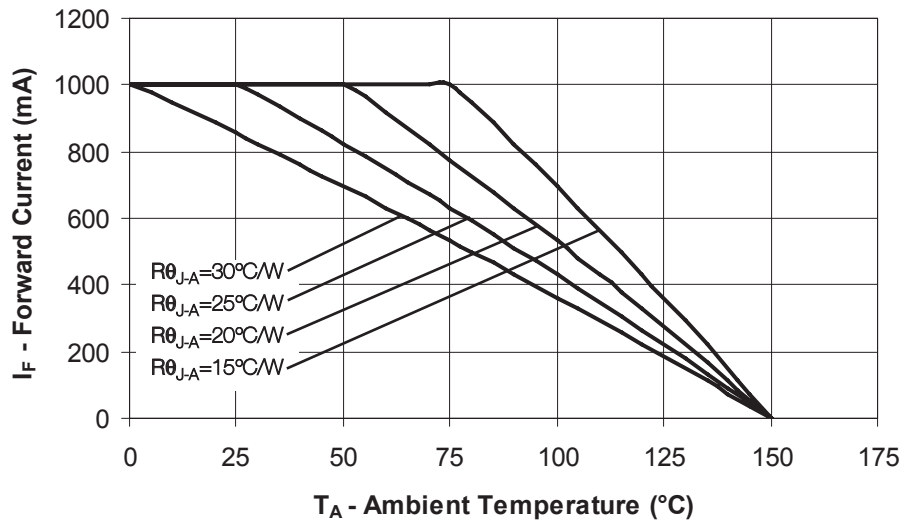

Figure 19: Maximum forward current vs. ambient temperature, based on  $T_{JMAX} = 150^{\circ}C$ .

## Current Derating Curve for 1500 mA Drive Current Cool-White, Neutral-White, Warm-White, Green, Cyan, Blue and Royal Blue

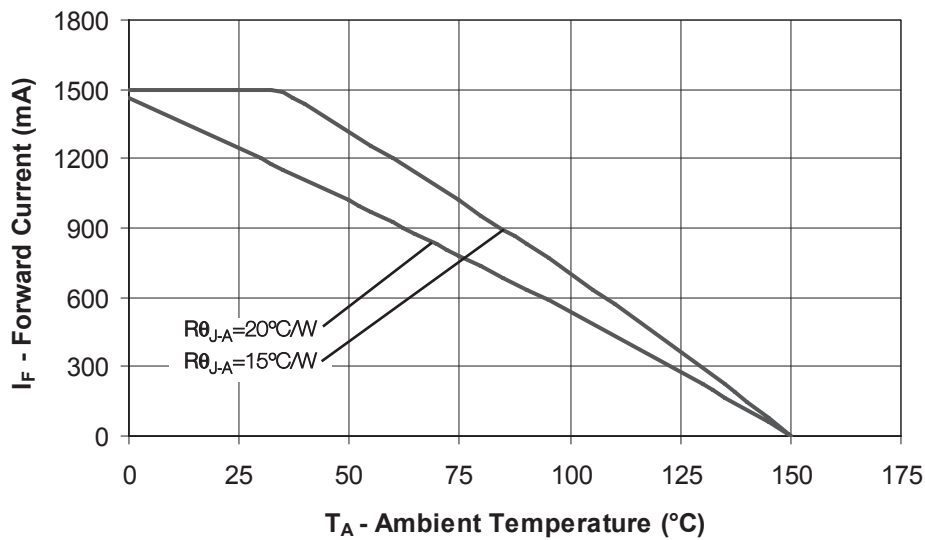

Figure 20: Maximum forward current vs. ambient temperature, based on  $T_{JMAX} = 150^{\circ}C$ .

## Typical Radiation Patterns

### Typical Representative Spatial Radiation Pattern for White Lambertian

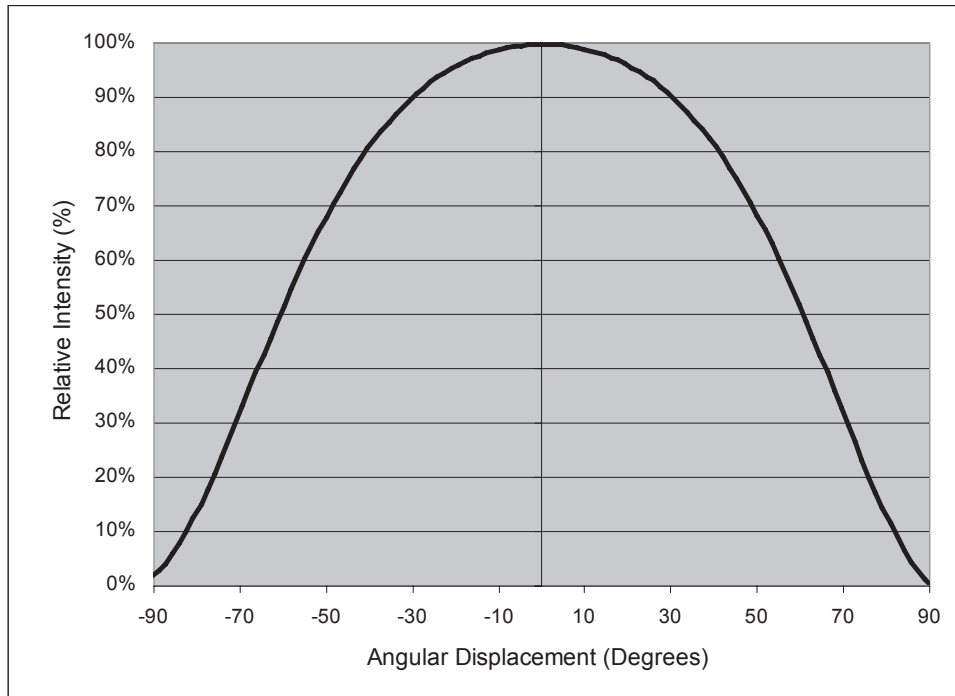

Figure 21: Typical Representative Spatial Radiation Pattern for White Lambertian.

### Typical Polar Radiation Pattern for White Lambertian

TBD

Figure 22: Typical Polar Radiation Pattern for White Lambertian.

---

## Typical Representative Spatial Radiation Pattern for Green, Cyan, Blue and Royal Blue Lambertian

TBD

Figure 23: Typical Representative Spatial Radiation Pattern for Green, Cyan, Blue and Royal Blue Lambertian.

## Typical Polar Radiation Pattern for Green, Cyan, Blue and Royal Blue Lambertian

TBD

Figure 24: Typical Polar Radiation Pattern for Green, Cyan, Blue and Royal Blue Lambertian.

# Emitter Reel Packaging

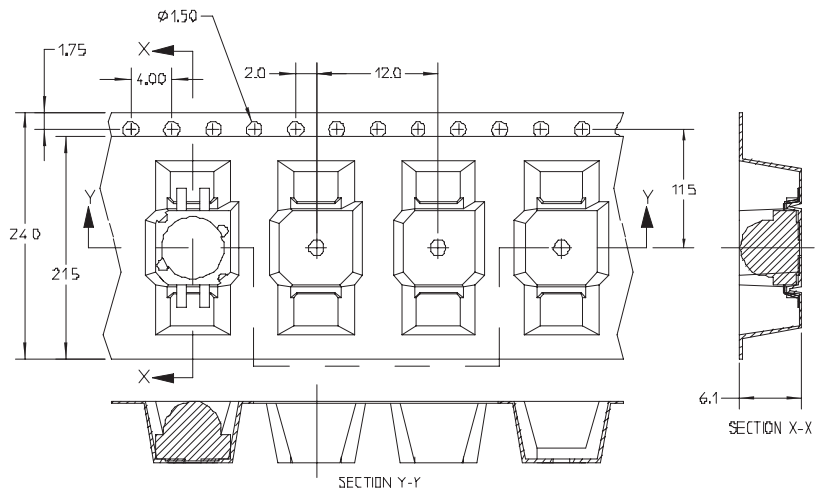
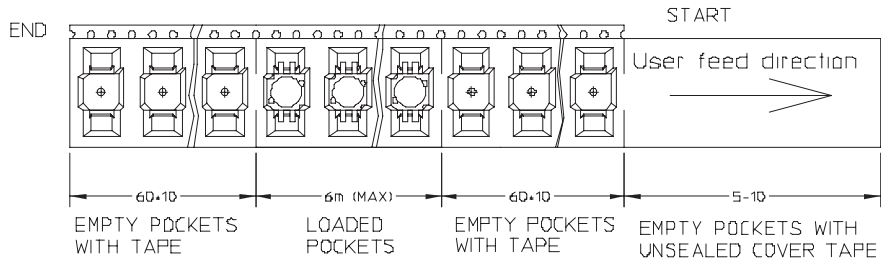
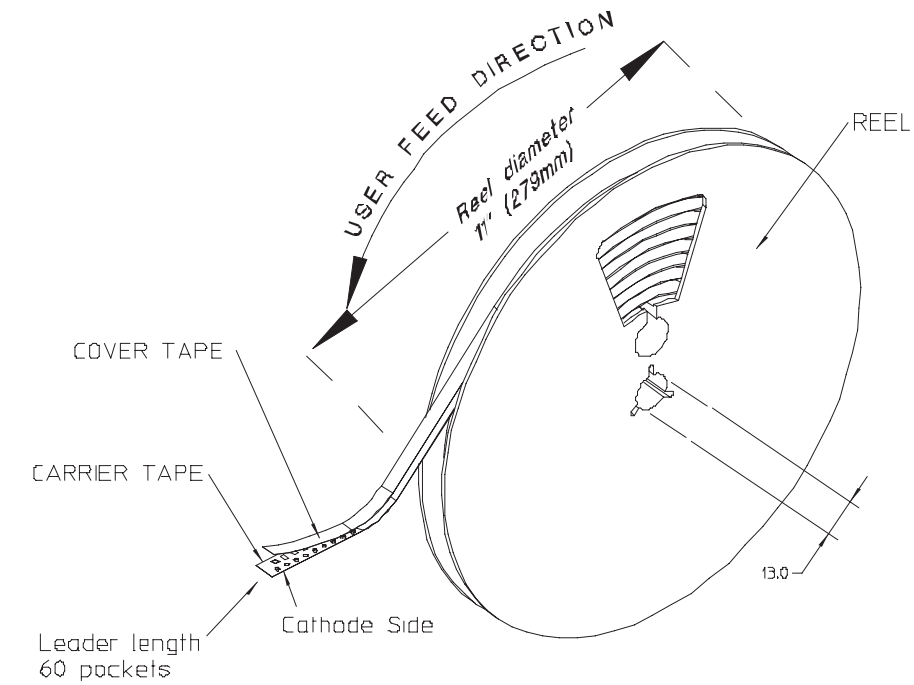

---

## Product Binning and Labeling

### Purpose of Product Binning

In the manufacturing of semiconductor products, there is a variation of performance around the average values given in the technical data sheets. For this reason, Philips Lumileds bins the LED components for luminous flux, color and forward voltage ( $V_F$ ).

### Decoding Product Bin Labeling

LUXEON K2 with TFFC Emitters are labeled using a three or four digit alphanumeric code (CAT code) depicting the bin values for emitters packaged on a single reel. All emitters packaged within a reel are of the same 3-variable bin combination. Using these codes, it is possible to determine optimum mixing and matching of products for consistency in a given application.

### Format of Labeling for Emitters

Reels of Green, Cyan, Blue and Royal-Blue Emitters are labeled with a three digit alphanumeric CAT code following the format below.

ABC

A = Flux bin (J, H, J, K etc.)

B = Color bin (2, 4, 6 etc.)

C =  $V_F$  bin (D, E, F, G etc.)

Reels of Cool-White, Neutral-White and Warm-White Emitters are labeled with a four digit alphanumeric CAT code following the format below.

ABCD

A = Flux bin (J, H, J, K etc.)

B and C = Color bin (W0, U0, V0 etc.)

C =  $V_F$  bin (D, E, F, G etc.)

## Luminous Flux Bins

Table 11 lists the standard photometric luminous flux bins for LUXEON K2 with TFFC emitters (at test current).

Although several bins are outlined, product availability in a particular bin varies by production run and by product performance. Not all bins are available in all colors.

Table 9.

| Flux Bins - All Colors (except Royal-Blue) |                               |                               |
|--|-------------------------------|-------------------------------|
| Bin Code                                   | Minimum Photometric Flux (lm) | Maximum Photometric Flux (lm) |
| A  | 8.2                           | 10.7                          |
| B  | 10.7                          | 13.9                          |
| C  | 13.9                          | 18.1                          |
| D  | 18.1                          | 23.5                          |
| E  | 23.5                          | 30                            |
| F  | 30                            | 40                            |
| G  | 40                            | 50                            |
| H  | 50                            | 60                            |
| J  | 60                            | 70                            |
| K  | 70                            | 80                            |
| L  | 80                            | 90                            |
| M  | 90                            | 100                           |
| N  | 100                           | 120                           |
| P  | 120                           | 140                           |
| Q  | 140                           | 160                           |
| R  | 160                           | 180                           |
| S  | 180                           | 200                           |
| T  | 200                           | 220                           |
| U  | 220                           | 260                           |
| V  | 260                           | 300                           |
| W  | 300                           | 350                           |
| X  | 350                           | 400                           |

Note: Please see Table 1 for binning parameters and tolerances.

Table 10.

## Flux Bins - Royal-Blue Only (at test current)

| Bin Code | Minimum Radiometric Flux (mW) | Maximum Radiometric Flux (mW) |
|----------|-------------------------------|-------------------------------|
| A        | 175                           | 225                           |
| B        | 225                           | 275                           |
| C        | 275                           | 350                           |
| D        | 350                           | 425                           |
| E        | 425                           | 500                           |
| F        | 500                           | 600                           |
| G        | 600                           | 700                           |
| H        | 700                           | 800                           |
| J        | 800                           | 900                           |
| K        | 900                           | 1000                          |

## Forward Voltage Bins

Although several bins are outlined, product availability in a particular bin varies by production run and by product performance.

Table 11.

V<sub>F</sub> Bins

| Bin Code | Minimum Forward Voltage (V) | Maximum Forward Voltage (V) |
|----------|-----------------------------|-----------------------------|
| A        | 2.31                        | 2.55                        |
| B        | 2.55                        | 2.79                        |
| C        | 2.79                        | 3.03                        |
| D        | 3.03                        | 3.27                        |
| E        | 3.27                        | 3.51                        |
| F        | 3.51                        | 3.75                        |
| G        | 3.75                        | 3.99                        |
| H        | 3.99                        | 4.23                        |
| J        | 4.23                        | 4.47                        |
| K        | 4.47                        | 4.71                        |
| L        | 4.71                        | 4.95                        |

Note: Please see Table 4 for more information on Forward Voltage binning.

# White Binning Information

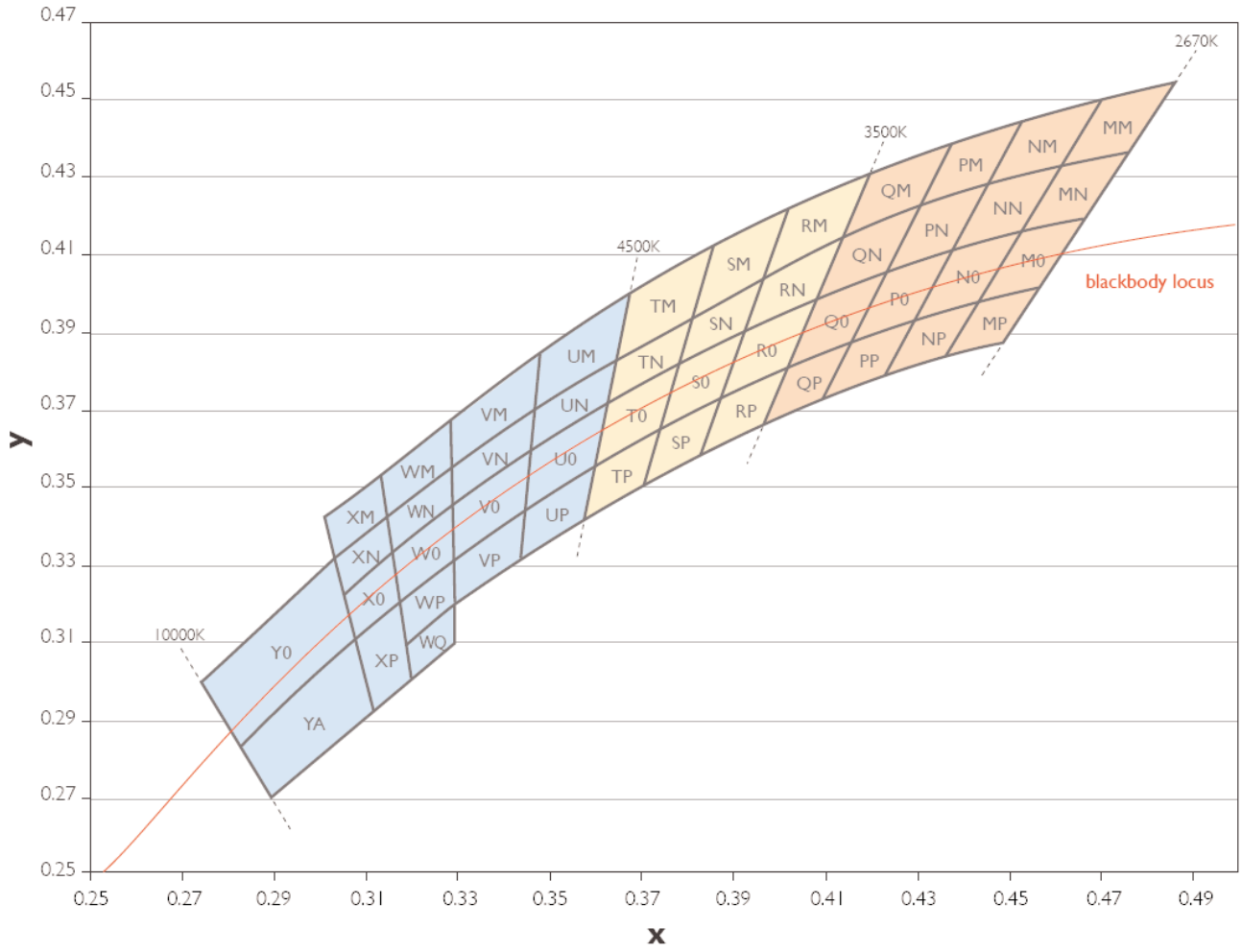

Figure 25: White Binning Structure

## LUXEON K2 with TFFC Cool-White Bin Structure

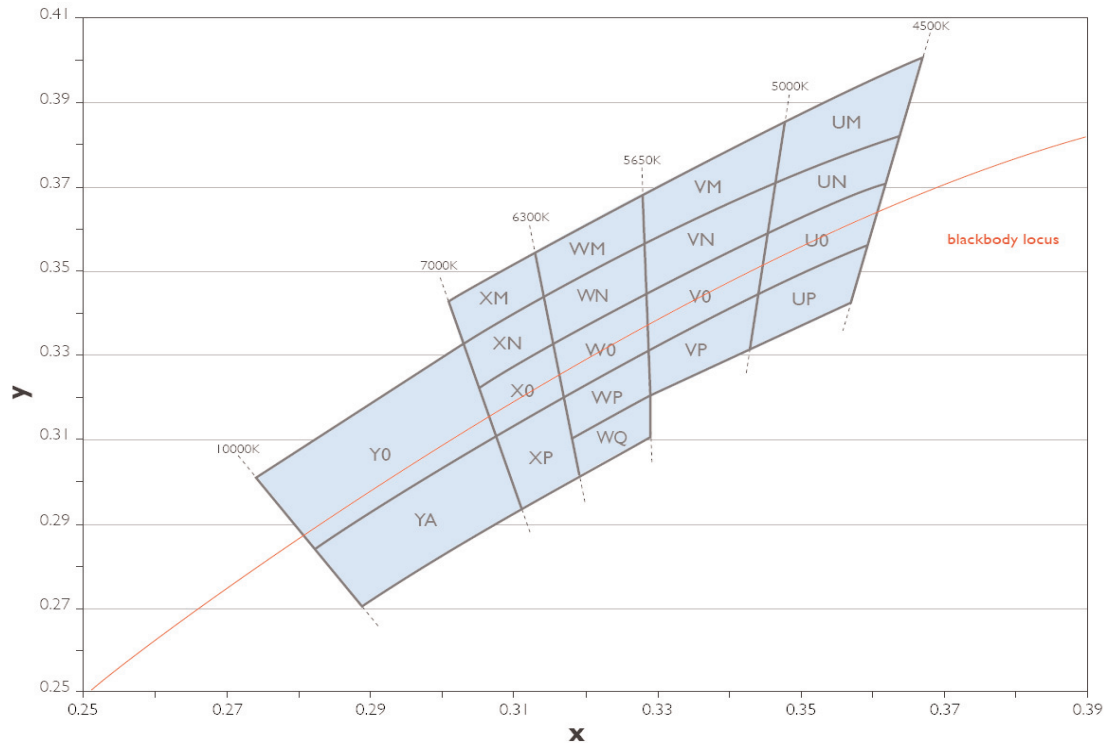

Figure 26: Cool-White Bin Structure

## LUXEON K2 with TFFC Cool-White Bin Structure, Continued

Cool-White LUXEON K2 with TFFC Emitters are tested and binned by x,y coordinates.

19 Color Bins, CCT Range 10,000K to 4,500K

Table 12.

| Cool White Bin Structure |          |          |                 |          |          |          |                 |
|--------------------------|----------|----------|-----------------|----------|----------|----------|-----------------|
| Bin Code                 | X        | Y        | Typical CCT (K) | Bin Code | X        | Y        | Typical CCT (K) |
| Y0                       | 0.274238 | 0.300667 | 8000            | WQ       | 0.318606 | 0.310201 | 6000            |
|                          | 0.303051 | 0.332708 |                 |          | 0.329393 | 0.320211 |                 |
|                          | 0.307553 | 0.310778 |                 |          | 0.329544 | 0.310495 |                 |
|                          | 0.282968 | 0.283772 |                 |          | 0.319597 | 0.301303 |                 |
| YA                       | 0.282968 | 0.283772 | 8000            | VM       | 0.328636 | 0.368952 | 5300            |
|                          | 0.307553 | 0.310778 |                 |          | 0.348147 | 0.385629 |                 |
|                          | 0.311163 | 0.293192 |                 |          | 0.346904 | 0.371742 |                 |
|                          | 0.289922 | 0.270316 |                 |          | 0.328823 | 0.356917 |                 |
| XM                       | 0.301093 | 0.342244 | 6700            | VN       | 0.328823 | 0.356917 | 5300            |
|                          | 0.313617 | 0.354992 |                 |          | 0.346904 | 0.371742 |                 |
|                          | 0.314792 | 0.344438 |                 |          | 0.345781 | 0.359190 |                 |
|                          | 0.303051 | 0.332708 |                 |          | 0.329006 | 0.345092 |                 |
| XN                       | 0.303051 | 0.332708 | 6700            | V0       | 0.329006 | 0.345092 | 5300            |
|                          | 0.314792 | 0.344438 |                 |          | 0.345781 | 0.359190 |                 |
|                          | 0.316042 | 0.333222 |                 |          | 0.344443 | 0.344232 |                 |
|                          | 0.305170 | 0.322386 |                 |          | 0.329220 | 0.331331 |                 |
| X0                       | 0.305170 | 0.322386 | 6700            | VP       | 0.329220 | 0.331331 | 5300            |
|                          | 0.316042 | 0.333222 |                 |          | 0.344443 | 0.344232 |                 |
|                          | 0.317466 | 0.320438 |                 |          | 0.343352 | 0.332034 |                 |
|                          | 0.307553 | 0.310778 |                 |          | 0.329393 | 0.320211 |                 |
| XP                       | 0.307553 | 0.310778 | 6700            | UM       | 0.348147 | 0.385629 | 4750            |
|                          | 0.317466 | 0.320438 |                 |          | 0.367294 | 0.400290 |                 |
|                          | 0.319597 | 0.301303 |                 |          | 0.364212 | 0.382878 |                 |
|                          | 0.311163 | 0.293192 |                 |          | 0.346904 | 0.371742 |                 |
| WM                       | 0.313617 | 0.354992 | 6000            | UN       | 0.346904 | 0.371742 | 4750            |
|                          | 0.328636 | 0.368952 |                 |          | 0.364212 | 0.382878 |                 |
|                          | 0.328823 | 0.356917 |                 |          | 0.362219 | 0.371616 |                 |
|                          | 0.314792 | 0.344438 |                 |          | 0.345781 | 0.359190 |                 |
| WN                       | 0.314792 | 0.344438 | 6000            | U0       | 0.345781 | 0.359190 | 4750            |
|                          | 0.328823 | 0.356917 |                 |          | 0.362219 | 0.371616 |                 |
|                          | 0.329006 | 0.345092 |                 |          | 0.359401 | 0.355699 |                 |
|                          | 0.316042 | 0.333222 |                 |          | 0.344443 | 0.344232 |                 |
| W0                       | 0.316042 | 0.333222 | 6000            | UP       | 0.344443 | 0.344232 | 4750            |
|                          | 0.329006 | 0.345092 |                 |          | 0.359401 | 0.355699 |                 |
|                          | 0.329220 | 0.331331 |                 |          | 0.357079 | 0.342581 |                 |
|                          | 0.317466 | 0.320438 |                 |          | 0.343352 | 0.332034 |                 |
| WP                       | 0.317466 | 0.320438 | 6000            |          |          |          |                 |
|                          | 0.329220 | 0.331331 |                 |          |          |          |                 |
|                          | 0.329393 | 0.320211 |                 |          |          |          |                 |
|                          | 0.318606 | 0.310201 |                 |          |          |          |                 |

Note for Table 12:

1. Philips Lumileds maintains a tester tolerance of  $\pm 0.005$  on x, y color coordinates.

## LUXEON K2 with TFFC Neutral-White Bin Structure

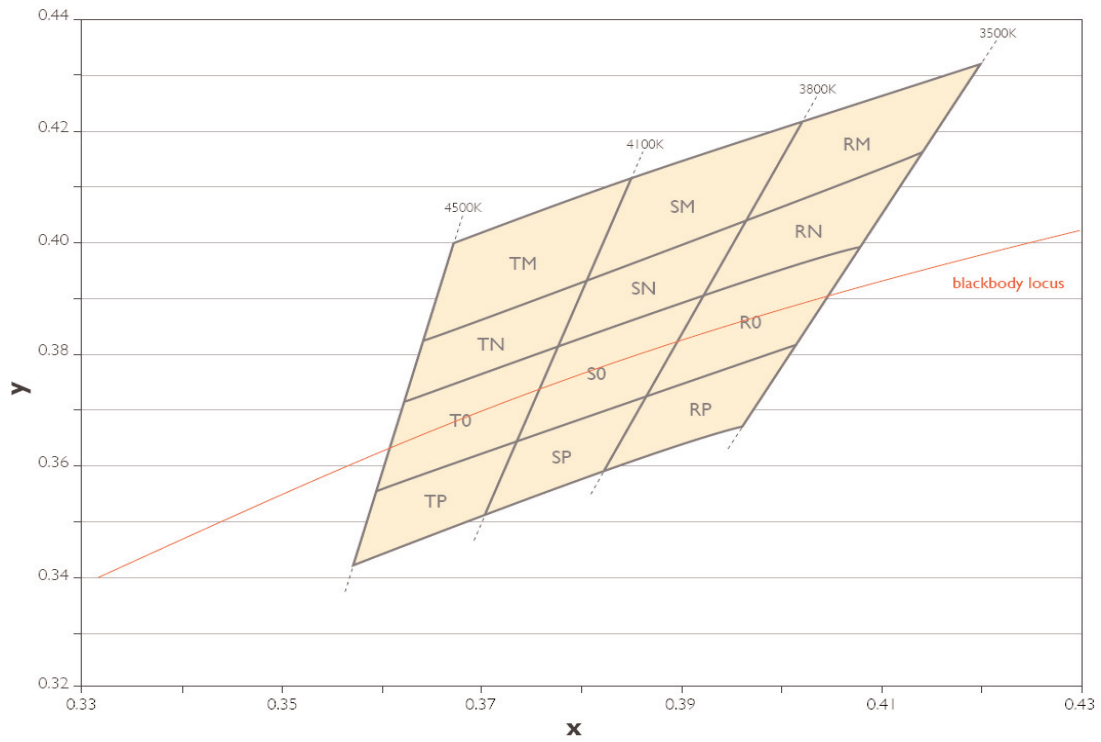

Figure 27: Neutral-White Bin Structure.

## LUXEON K2 with TFFC Neutral-White Bin Structure, Continued

Neutral-White LUXEON K2 with TFFC Emitters are tested and binned by x,y coordinates.  
12 Color Bins, CCT Range 4,500K to 3,500K

Table 13.

| Neutral-White Bin Structure |          |          |                 |          |          |          |                 |
|-----------------------------|----------|----------|-----------------|----------|----------|----------|-----------------|
| Bin Code                    | X        | Y        | Typical CCT (K) | Bin Code | X        | Y        | Typical CCT (K) |
| TM                          | 0.367294 | 0.400290 | 4300            | S0       | 0.378264 | 0.382458 | 3950            |
|                             | 0.385953 | 0.412995 |                 |          | 0.392368 | 0.390932 |                 |
|                             | 0.381106 | 0.393747 |                 |          | 0.387071 | 0.373899 |                 |
|                             | 0.364212 | 0.382878 |                 |          | 0.374075 | 0.365822 |                 |
| TN                          | 0.364212 | 0.382878 | 4300            | SP       | 0.374075 | 0.365822 | 3950            |
|                             | 0.381106 | 0.393747 |                 |          | 0.387071 | 0.373899 |                 |
|                             | 0.378264 | 0.382458 |                 |          | 0.382598 | 0.359515 |                 |
|                             | 0.362219 | 0.371616 |                 |          | 0.370582 | 0.351953 |                 |
| T0                          | 0.362219 | 0.371616 | 4300            | RM       | 0.402270 | 0.422776 | 3650            |
|                             | 0.378264 | 0.382458 |                 |          | 0.420940 | 0.432618 |                 |
|                             | 0.374075 | 0.365822 |                 |          | 0.414776 | 0.416097 |                 |
|                             | 0.359401 | 0.355699 |                 |          | 0.396279 | 0.403508 |                 |
| TP                          | 0.359401 | 0.355699 | 4300            | RN       | 0.396279 | 0.403508 | 3650            |
|                             | 0.374075 | 0.365822 |                 |          | 0.414776 | 0.416097 |                 |
|                             | 0.370582 | 0.351953 |                 |          | 0.408593 | 0.399525 |                 |
|                             | 0.357079 | 0.342581 |                 |          | 0.392368 | 0.390932 |                 |
| SM                          | 0.385953 | 0.412995 | 3950            | R0       | 0.392368 | 0.390932 | 3650            |
|                             | 0.402270 | 0.422776 |                 |          | 0.408593 | 0.399525 |                 |
|                             | 0.396279 | 0.403508 |                 |          | 0.402113 | 0.382156 |                 |
|                             | 0.381106 | 0.393747 |                 |          | 0.387071 | 0.373899 |                 |
| SN                          | 0.381106 | 0.393747 | 3950            | RP       | 0.387071 | 0.373899 | 3650            |
|                             | 0.396279 | 0.403508 |                 |          | 0.402113 | 0.382156 |                 |
|                             | 0.392368 | 0.390932 |                 |          | 0.396564 | 0.367284 |                 |
|                             | 0.378264 | 0.382458 |                 |          | 0.382598 | 0.359515 |                 |

Note for Table 13:

1. Philips Lumileds maintains a tester tolerance of  $\pm 0.005$  on x, y color coordinates.

# LUXEON K2 with TFFC Warm-White Bin Structure

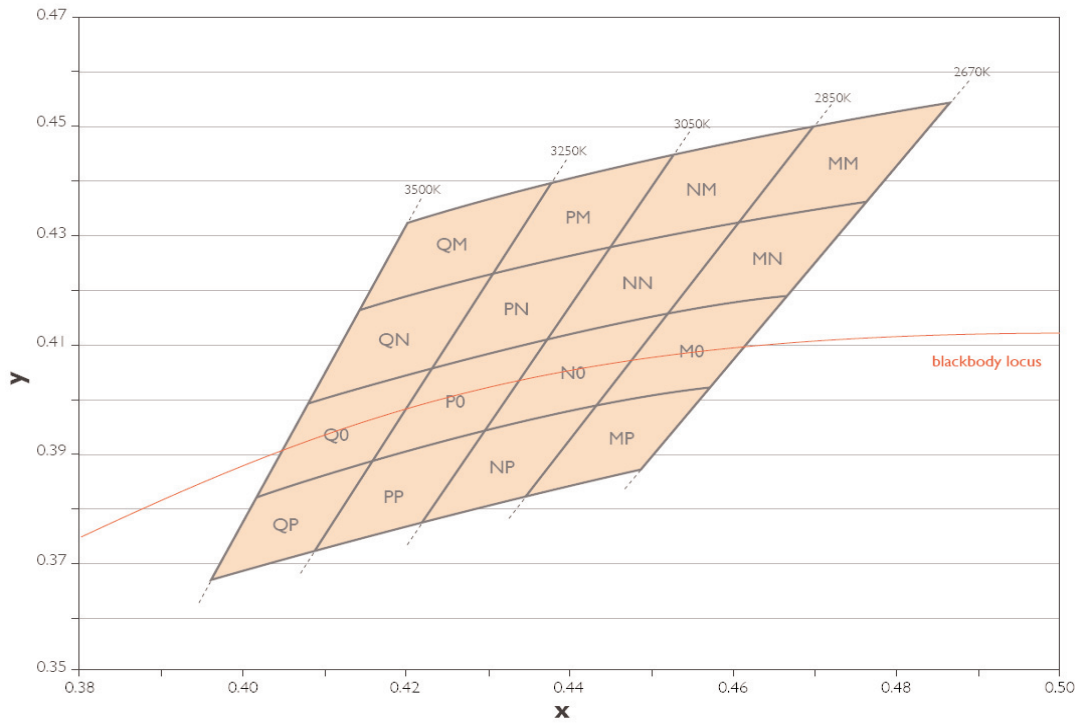

Figure 28: Warm-White Bin Structure.

## LUXEON K2 with TFFC Warm-White Bin Structure, Continued

Warm-White LUXEON K2 with TFFC Emitters are tested and binned by x,y coordinates.  
16 Color Bins, CCT Range 3,500K to 2,670K

Table 14.

| Warm-White Bin Structure |          |          |                 |          |          |          |                 |
|--------------------------|----------|----------|-----------------|----------|----------|----------|-----------------|
| Bin Code                 | X        | Y        | Typical CCT (K) | Bin Code | X        | Y        | Typical CCT (K) |
| QM                       | 0.420940 | 0.432618 | 3375            | NM       | 0.453820 | 0.445980 | 2950            |
|                          | 0.438458 | 0.440399 |                 |          | 0.470507 | 0.450832 |                 |
|                          | 0.431186 | 0.423386 |                 |          | 0.461404 | 0.433334 |                 |
|                          | 0.414776 | 0.416097 |                 |          | 0.445639 | 0.428680 |                 |
| QN                       | 0.414776 | 0.416097 | 3375            | NN       | 0.445639 | 0.428680 | 2950            |
|                          | 0.431186 | 0.423386 |                 |          | 0.461404 | 0.433334 |                 |
|                          | 0.423956 | 0.406472 |                 |          | 0.452512 | 0.416241 |                 |
|                          | 0.408593 | 0.399525 |                 |          | 0.437578 | 0.411632 |                 |
| QO                       | 0.408593 | 0.399525 | 3375            | NO       | 0.437578 | 0.411632 | 2950            |
|                          | 0.423956 | 0.406472 |                 |          | 0.452512 | 0.416241 |                 |
|                          | 0.416487 | 0.389001 |                 |          | 0.443600 | 0.399111 |                 |
|                          | 0.402113 | 0.382156 |                 |          | 0.429373 | 0.394281 |                 |
| QP                       | 0.402113 | 0.382156 | 3375            | NP       | 0.429373 | 0.394281 | 2950            |
|                          | 0.416487 | 0.389001 |                 |          | 0.443600 | 0.399111 |                 |
|                          | 0.409996 | 0.373814 |                 |          | 0.435591 | 0.383714 |                 |
|                          | 0.396564 | 0.367284 |                 |          | 0.422124 | 0.378952 |                 |
| PM                       | 0.438458 | 0.440399 | 3150            | MM       | 0.470507 | 0.450832 | 2760            |
|                          | 0.453820 | 0.445980 |                 |          | 0.486648 | 0.454191 |                 |
|                          | 0.445639 | 0.428680 |                 |          | 0.476733 | 0.436634 |                 |
|                          | 0.431186 | 0.423386 |                 |          | 0.461404 | 0.433334 |                 |
| PN                       | 0.431186 | 0.423386 | 3150            | MN       | 0.461404 | 0.433334 | 2760            |
|                          | 0.445639 | 0.428680 |                 |          | 0.476733 | 0.436634 |                 |
|                          | 0.437578 | 0.411632 |                 |          | 0.467132 | 0.419632 |                 |
|                          | 0.423956 | 0.406472 |                 |          | 0.452512 | 0.416241 |                 |
| PO                       | 0.423956 | 0.406472 | 3150            | MO       | 0.452512 | 0.416241 | 2760            |
|                          | 0.437578 | 0.411632 |                 |          | 0.467132 | 0.419632 |                 |
|                          | 0.429373 | 0.394281 |                 |          | 0.457663 | 0.402866 |                 |
|                          | 0.416487 | 0.389001 |                 |          | 0.443600 | 0.399111 |                 |
| PP                       | 0.416487 | 0.389001 | 3150            | MP       | 0.443600 | 0.399111 | 2760            |
|                          | 0.429373 | 0.394281 |                 |          | 0.457663 | 0.402866 |                 |
|                          | 0.422124 | 0.378952 |                 |          | 0.448994 | 0.387515 |                 |
|                          | 0.409996 | 0.373814 |                 |          | 0.435591 | 0.383714 |                 |

Note for Table 14:

1. Philips Lumileds maintains a tester tolerance of  $\pm 0.005$  on x, y color coordinates.

## Color Bins

### Dominant Wavelength Bin Structure for Green Emitters

Table 15.

| Bin Code | Minimum Dominant Wavelength (nm) | Maximum Dominant Wavelength (nm) |
|----------|----------------------------------|----------------------------------|
| 1        | 520                              | 525                              |
| 2        | 525                              | 530                              |
| 3        | 530                              | 535                              |
| 4        | 535                              | 540                              |
| 5        | 540                              | 545                              |
| 6        | 545                              | 550                              |

### Dominant Wavelength Bin Structure for Cyan Emitters

Table 16.

| Bin Code | Minimum Dominant Wavelength (nm) | Maximum Dominant Wavelength (nm) |
|----------|----------------------------------|----------------------------------|
| 1        | 490                              | 495                              |
| 2        | 495                              | 500                              |
| 3        | 500                              | 505                              |
| 4        | 505                              | 510                              |
| 5        | 510                              | 515                              |
| 6        | 515                              | 520                              |

### Dominant Wavelength Bin Structure for Blue Emitters

Table 17.

| Bin Code | Minimum Dominant Wavelength (nm) | Maximum Dominant Wavelength (nm) |
|----------|----------------------------------|----------------------------------|
| 1        | 460                              | 465                              |
| 2        | 465                              | 470                              |
| 3        | 470                              | 475                              |
| 4        | 475                              | 480                              |
| 5        | 480                              | 485                              |
| 6        | 485                              | 490                              |

### Peak Wavelength Bin Structure for Royal-Blue Emitters

Table 18.

| Bin Code | Minimum Peak Wavelength (nm) | Maximum Peak Wavelength (nm) |
|----------|------------------------------|------------------------------|
| 3        | 440                          | 445                          |
| 4        | 445                          | 450                          |
| 5        | 450                          | 455                          |
| 6        | 455                          | 460                          |
| 7        | 460                          | 465                          |
| 8        | 465                          | 470                          |

Note: Please see Table 3 for binning parameters and tolerances.



### Company Information

Philips Lumileds Lighting Company is a world class supplier of Light Emitting Diodes (LEDs) and produces billions of LEDs annually. Philips Lumileds is a fully integrated supplier producing core LED material in all three base colors (red, green, blue) and white. Philips Lumileds has R&D centers in San Jose, California and in The Netherlands as well as production capabilities in San Jose, Penang Malaysia and Singapore. Founded in 1999, Philips Lumileds is the high-flux LED technology leader and is dedicated to bridging the gap between solid-state LED technology and the lighting world. Philips Lumileds technologies, LEDs and systems are enabling new applications and markets in the lighting world.

Philips Lumileds may make process or materials changes affecting the performance or other characteristics of our products. These products supplied after such changes will continue to meet published specifications, but may not be identical to products supplied as samples or under prior orders.



[WWW.LUXEON.COM](http://WWW.LUXEON.COM)  
[WWW.LUMILEDSFUTURE.COM](http://WWW.LUMILEDSFUTURE.COM)

FOR TECHNICAL ASSISTANCE OR THE LOCATION OF YOUR NEAREST SALES OFFICE CONTACT ANY OF THE FOLLOWING:

**NORTH AMERICA:**  
1 888 589 3662  
[AMERICAS@FUTURELIGHTINGSOLUTIONS.COM](mailto:AMERICAS@FUTURELIGHTINGSOLUTIONS.COM)

**EUROPE:**  
OO 800 443 88 873  
[EUROPE@FUTURELIGHTINGSOLUTIONS.COM](mailto:EUROPE@FUTURELIGHTINGSOLUTIONS.COM)

**ASIA PACIFIC:**  
800 5864 5337  
[ASIA@FUTURELIGHTINGSOLUTIONS.COM](mailto:ASIA@FUTURELIGHTINGSOLUTIONS.COM)

**JAPAN:**  
800 5864 5337  
[JAPAN@FUTURELIGHTINGSOLUTIONS.COM](mailto:JAPAN@FUTURELIGHTINGSOLUTIONS.COM)

©2007 Philips Lumileds Lighting Company. All rights reserved. Product specifications are subject to change without notice. Luxeon is a registered trademark of the Philips Lumileds Lighting Company in the United States and other countries.

---